

PALLET HANDLING EQUIPMENT

HEAVY-DUTY SERIES

Rugged construction makes these pallet trucks the best value for your material handling needs. Forks feature entry rollers and tapered design for easy pallet entry and are reinforced for heavy-duty loads. The 3-function hand control (raise, neutral and lower) and the spring-loaded self-righting safety loop handle enhance comfort and ease of operation. Hardened chrome piston with protective dust cover for dependable performance. Durable powder coat finish.

HYDRAULIC PALLET TRUCKS

- Heavy-duty polyurethane tread bonded to cast iron core steering wheels and rollers provide superior performance
- 6 1/4" (158.75 mm) wide forks
- High visibility orange
- **2-year limited warranty**



| Model No. | Forks | | Frame Width" | Fork Length" | Capacity lbs. |
|-----------|----------|---------|--------------|--------------|---------------|
| | Lowered" | Raised" | | | |
| MJ484 | 2 7/8 | 7 3/4 | 20 1/2 | 36 | 5500 |
| MJ485 | 2 7/8 | 7 3/4 | 20 1/2 | 42 | 5500 |
| MJ486 | 2 7/8 | 7 3/4 | 20 1/2 | 48 | 5500 |
| MJ487 | 2 7/8 | 7 3/4 | 27 | 36 | 5500 |
| MJ488 | 2 7/8 | 7 3/4 | 27 | 42 | 5500 |
| MJ489 | 2 7/8 | 7 3/4 | 27 | 48 | 5500 |
| ML372* | 2 7/8 | 7 3/4 | 27 | 48 | 5500 |

* Heavy-duty nylon wheels

HYDRAULIC PALLET TRUCKS

- Heavy-duty polyurethane tread bonded to cast iron core steering wheels and rollers provide superior performance
- Double rollers for easy moving of extra heavy loads
- Reinforced fork channels deliver exceptional durability
- 6 1/4" (158.75 mm) wide forks
- Kleton blue
- **2-year limited warranty**

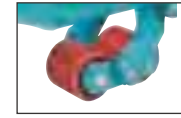

Forks feature double entry rollers and tapered design for easy pallet entry

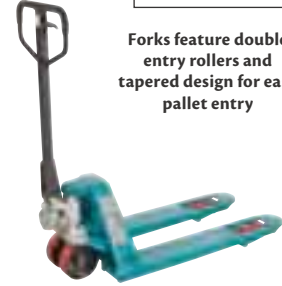

| Model No. | Forks | | Frame Width" | Fork Length" | Capacity lbs. |
|-----------|----------|---------|--------------|--------------|---------------|
| | Lowered" | Raised" | | | |
| MJ490 | 2 7/8 | 7 3/4 | 20 1/2 | 36 | 6600 |
| MJ491 | 2 7/8 | 7 3/4 | 20 1/2 | 42 | 6600 |
| MJ492 | 2 7/8 | 7 3/4 | 20 1/2 | 48 | 6600 |
| MJ493 | 2 7/8 | 7 3/4 | 27 | 36 | 6600 |
| MJ494 | 2 7/8 | 7 3/4 | 27 | 42 | 6600 |
| MJ495 | 2 7/8 | 7 3/4 | 27 | 48 | 6600 |
| ML373* | 2 7/8 | 7 3/4 | 27 | 48 | 6600 |

* Heavy-duty nylon wheels

STANDARD-DUTY HYDRAULIC PALLET TRUCKS

- Heavy-duty polyurethane tread bonded to cast iron core steering wheels and rollers provide superior performance
- Heavy-duty plastic rollers facilitate entry and exit of pallets
- 6 1/4" (158.75 mm) wide forks
- High visibility yellow
- **1-year limited warranty**



| Model No. | Forks | | Frame Width" | Fork Length" | Capacity lbs. |
|-----------|----------|---------|--------------|--------------|---------------|
| | Lowered" | Raised" | | | |
| ML966 | 3 1/4 | 7 3/4 | 20 1/2 | 36 | 5500 |
| ML967 | 3 1/4 | 7 3/4 | 20 1/2 | 42 | 5500 |
| ML968 | 3 1/4 | 7 3/4 | 20 1/2 | 48 | 5500 |
| ML969 | 3 1/4 | 7 3/4 | 27 | 36 | 5500 |
| ML970 | 3 1/4 | 7 3/4 | 27 | 42 | 5500 |
| ML971 | 3 1/4 | 7 3/4 | 27 | 48 | 5500 |
| ML972* | 3 1/4 | 7 3/4 | 27 | 48 | 5500 |

* All nylon core steering wheels and rollers

SUPER HEAVY-DUTY HYDRAULIC PALLET TRUCK

- Extra heavy-duty all steel steering wheels and rollers provide maximum mobility and performance
- Double rollers for easy moving of extra heavy loads
- Heavy-duty plastic exit rollers facilitate entry and exit of pallets
- 6 1/4" (158.75 mm) wide forks
- Dark blue
- **2-year limited warranty**



| Model No. | Forks | | Frame Width" | Fork Length" | Capacity lbs. |
|-----------|----------|---------|--------------|--------------|---------------|
| | Lowered" | Raised" | | | |
| ML994 | 3 | 7 3/8 | 27 | 48 | 11000 |

6' LONG FORK HYDRAULIC PALLET TRUCKS

- Heavy-duty polyurethane tread bonded to cast iron core steering wheels and rollers provide superior performance
- Nylon exit roller facilitates entry and exit of pallets
- 6 1/4" (158.75 mm) wide forks
- Lowered pallet truck height: 3"
- Raised pallet truck height: 7 5/8"
- Capacity: Up to 5500 lbs.
- High visibility yellow
- **2-year limited warranty**



| Model No. | Fork Width" | Fork Length" |
|-----------|-------------|--------------|
| MN459 | 27 | 72 |

LOW PROFILE HYDRAULIC PALLET TRUCKS

- Permits the handling of pallets and containers that are lower than the standard height
- Heavy-duty polyurethane tread bonded to cast iron core steering wheels and all steel rollers provide superior performance
- 1.5" exit ramp facilitates exit of pallets
- 6" (152 mm) wide forks
- Lowered pallet truck height: 2"
- Raised pallet truck height: 5 1/2"
- High visibility orange
- **2-year limited warranty**



| Model No. | Frame Width" | Fork Length" | Capacity lbs. |
|-----------|--------------|--------------|---------------|
| MN061 | 27 | 48 | 5500 |

PALLET HANDLING EQUIPMENT

MULTI-DIRECTIONAL HYDRAULIC PALLET TRUCKS

- Transrollers permit lateral movement in addition to forward/backward
- Heavy-duty polyurethane tread bonded to cast iron core steering wheels provide superior performance
- Double load rollers, one polyurethane tread bonded to cast iron core and one nylon for easy moving of extra heavy loads
- 2 1/5" exit ramp facilitates exit of pallets
- 6 1/4" (158.75 mm) wide forks
- Lowered pallet truck height: 3"
- Raised pallet truck height: 7 1/2"
- Capacity: Up to 5500 lbs. in standard mode and up to 3300 lbs. in lateral mode
- High visibility orange
- **2-year limited warranty**



| Model No. | Frame Width" | Fork Length" |
|-----------|--------------|--------------|
| MN062 | 27 | 48 |



DIGITAL SCALE HYDRAULIC PALLET TRUCKS

- Permits the weighing of skids and containers while handling them
- Mettler Toledo digital cUL listed scale offers maximum precision on load weights
- Heavy-duty polyurethane tread bonded to cast iron core steering wheels and rollers provide superior performance
- Nylon roller facilitates entry and exit of pallets
- 6 5/8" (168 mm) wide forks
- Lowered pallet truck height: 3"
- Raised pallet truck height: 7 11/16"
- High visibility orange
- **2-year limited warranty**



| Model No. | Frame Width" | Fork Length" | Capacity lbs. |
|-----------|--------------|--------------|---------------|
| MN063 | 27 | 44 1/2 | 4400 |



GALVANIZED HYDRAULIC PALLET TRUCKS

- Heavy-duty all nylon steering wheels and rollers provide superior mobility and performance
- Nylon exit roller facilitates entry and exit of pallets
- 6 1/4" (158.75 mm) wide forks
- Lowered pallet truck height: 3"
- Raised pallet truck height: 7 1/16"
- Galvanized finish offers corrosion resistance and is ideal for wet and cold conditions
- **2-year limited warranty**



| Model No. | Frame Width" | Fork Length" | Capacity lbs. |
|-----------|--------------|--------------|---------------|
| MN059 | 27 | 48 | 5500 |
| MN648 | 27 | 42 | 5500 |



STAINLESS STEEL HYDRAULIC PALLET TRUCKS

- Heavy-duty all nylon steering wheels and rollers provide superior mobility and performance
- Nylon exit roller facilitates entry and exit of pallets
- 6 1/4" (158.75 mm) wide forks
- High grade 304 stainless steel is ideal for medical, food, sanitary, pharmaceutical, wet and cold applications
- **2-year limited warranty**



| Model No. | Fork Height Lowered" | Fork Height Raised" | Frame Width" | Fork Length" | Capacity lbs. |
|-----------|----------------------|---------------------|--------------|--------------|---------------|
| MN060 | 3 | 7 1/16 | 27 | 48 | 5500 |



4-WAY HYDRAULIC PALLET TRUCKS

- Can enter pallet from all four sides
- Reinforced forks
- Adjustable fork connecting rods
- Steel 1.70" load wheels
- 6" polyurethane steering wheels
- **3-year limited warranty**



| Model No. | Frame Width" | Fork Length" | Capacity lbs. |
|-----------|--------------|--------------|---------------|
| MN136 | 33 | 48 | 4000 |



ECO I-55 AUTOMOTIVE BRAKE PALLET TRUCK

- Quality german-designed pump
- 200 degree handle pivot
- Ergonomic cushioned handle
- 3-position finger tip control
- High-quality powder coat finish
- Polyurethane wheels and load rollers
- Fork width: 6.3"
- Raised height: 7.9"
- Lowered height: 2.9"



| Model No. | Frame Width" | Fork Length" | Capacity lbs. |
|-----------|--------------|--------------|---------------|
| LU002 | 27 | 48 | 5500 |



PALLET HANDLING EQUIPMENT

ADJUSTABLE WIDTH PALLET TRUCKS

- Overall fork width adjusts from 21" to 27"
- Fork length: 48"
- 7" mold-on polyurethane steering wheel
- 3" mold-on polyurethane load wheels
- 6" (152 mm) wide forks
- Raised height: 7 3/4"
- Lowered height: 3"
- Capacity: 5500 lbs.
- **5-year limited warranty**

Model No. MI820



ALL TERRAIN PALLET TRUCKS

- Welded steel tubular frame construction for maximum strength
- Features large pneumatic wheels for use on gravel, dirt and other types of rough terrain
- Wheels include sealed bearings for dust protection and long life
- Overall fork length: 32"
- Fork lowered height: 3"
- Fork raised height: 9"
- Overall dimensions: 64" W x 50" L x 51" H
- Usable straddle width is 50" between outriggers
- Rear wheel diameter: 10"
- **90-day limited warranty**



MN461

| Model No. | Capacity lbs. | Overall Fork Width | Wt. lbs. |
|-----------|--------------------------|--------------------|----------|
| MN461 | 2000* | 9 1/2" - 26" | 239 |
| MN462 | 2500** | 10" - 26 3/4" | 457 |
| MN463 | Optional Tow Bar Package | | 20 |

* 2,000 lbs. at 12" horizontal load center, 1,500 lbs. at 15" and 1,000 lbs at 24".
 ** 2,500 lbs. at 12" horizontal load center, 2,000 lbs. at 15" and 1,500 lbs at 24".

QUICK LIFT HYDRAULIC PALLET TRUCKS

- Maximize operator efficiency with this quick-lift pallet truck
- Lifts to full height with only four pumps when empty
- 2-speed pump automatically switches to low-speed operation
- Allows forks to quickly rise to upper pallet boards for quicker operation
- Each fork measures 6 1/4" wide
- Poly-on-steel wheels are the best in the industry
- **90-day limited warranty**



| Model No. | Fork Height | | Frame Width" | Fork Length" | Capacity lbs. |
|-----------|-------------|---------|--------------|--------------|---------------|
| | Lowered" | Raised" | | | |
| MN365 | 3 | 7 1/2 | 20 | 48 | 5500 |
| MN366 | 3 | 7 1/2 | 27 | 48 | 5500 |

PALLET TRUCK CADDY

- Durable molded plastic
- Economical product will convert a standard pallet truck into a portable workstation in minutes
- Overall dimensions: 16 1/4" W x 7 3/4" D x 18 5/8" H
- **Includes:** Tool pockets on each side, pen and pencil tray, clipboard holder, built-in cup or can holder, and storage compartment

Model No. MN368



Model No. MN367

POWER-START TECHNOLOGY™ PALLET TRUCKS

THE RIGHT TOOL FOR ERGONOMIC PALLET MOTION!

- Reduces starting resistance even when truck is heavily loaded
- Select travel direction via option on handgrip, squeeze the handgrip, pump the tow bar and the truck is launched in the walking direction
- When handgrip is pressed downward, and tow bar raised, the truck is launched in the direction of the forks
- **2-year limited warranty**

Specifications:

- Forks: 27" W x 48" L
- Minimum fork height: 3"
- Maximum fork height: 7 1/2"
- Rated capacity: 5000 lbs.
- Weight: 188 lbs.

Model No. MH736

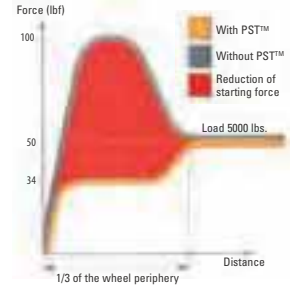

LIFT-RITE® TITAN PALLET TRUCKS

- New one-piece pump for improved performance and reliability
- Includes ergonomic handles and articulating steering wheels
- 7" wide forks
- Fork lowered height: 3"
- Fork raised height: 7 3/4"
- **2-year limited warranty**



| Model No | Frame Width" | Fork Length" | Capacity lbs. |
|----------|--------------|--------------|---------------|
| ML052 | 20 1/2 | 36 | 5500 |
| ML053 | 20 1/2 | 42 | 5500 |
| ML054 | 20 1/2 | 48 | 5500 |
| ML055 | 27 | 36 | 5500 |
| ML056 | 27 | 42 | 5500 |
| ML057 | 27 | 48 | 5500 |

Custom sizes available



UNIVERSAL PALLET TRUCK FOOTGUARDS

- Steel construction with powder-coat finish
- Prevents crushed toes and other foot injuries
- Universal design fits most manual hand pallet trucks
- Wraparound guard, floats up and down allowing for use on dock levelers and dock plates
- Offers full range of motion and does not interfere with normal pallet truck operation
- Width: 8"

Model No. MN367

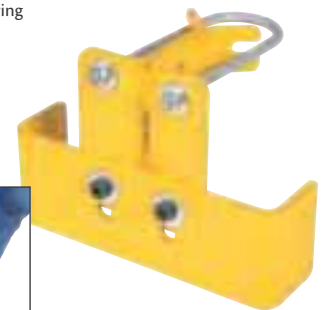

FORK EXTENSIONS

- Handle large and odd shaped loads with increased stability and minimum damage
- Available in 4", 5" and 6" fork widths, lengths are from 54" to 96"
- Easy to use slide-on design
- Fork fits up to 2" thick
- Convenient on/off design
- Locking bar keeps extensions in place
- Fork extension not to exceed 50% more than existing fork length



| Model No. | Accommodates Fork Width" | Fork Extension Overall Width" | Length" | Max. Fork Thickness" | Wt. lbs. |
|-----------|--------------------------|-------------------------------|---------|----------------------|----------|
| MF775 | 4 | 5 | 54 | 2 | 84 |
| MF776 | 4 | 5 | 63 | 2 | 98 |
| MF778 | 4 | 5 | 84 | 2 | 124 |
| MF781 | 5 | 6 | 54 | 2 | 96 |
| MF782 | 5 | 6 | 63 | 2 | 110 |
| MF784 | 5 | 6 | 84 | 2 | 129 |
| MF785 | 5 | 6 | 96 | 2 | 158 |
| MF787 | 6 | 7 | 54 | 2 1/2 | 104 |
| MF788 | 6 | 7 | 63 | 2 1/2 | 116 |
| MF789 | 6 | 7 | 72 | 2 1/2 | 134 |
| MF790 | 6 | 7 | 84 | 2 1/2 | 156 |
| MF791 | 6 | 7 | 96 | 2 1/2 | 181 |

Also available: Add-on for optional pins style fork extension and other lengths.

WALL BRACKETS

- All welded heavy-duty
- To keep fork extensions out of the way when not in use
- One wall bracket required for each pair of forks
- Kleton safety yellow



| Model No. | Dimensions W" x H" | Wt. lbs. |
|-----------|--------------------|----------|
| ML282 | 6 x 8 | 5 |

Hardware not included

FORK EXTENSIONS

- Handle large and odd shaped loads with increased stability
- Easy to use slide-on design
- Steel retaining strap prevents extensions from sliding off forks during use
- Fork extension not to exceed 50% more than existing fork length
- Available in 4" and 5" fork widths, with lengths of 72" and 96"



| Model No. | Accommodates Fork Width" | Fork Extension Overall Width" | Length" | Wt. lbs. |
|-----------|--------------------------|-------------------------------|---------|----------|
| ML346 | 4 | 5 | 72 | 105 |
| ML347 | 5 | 6 | 72 | 116 |
| ML348 | 4 | 5 | 96 | 140 |

CABLE REEL ROLLERS

- All welded, ready to use
- For winding or dispensing cable, chain, wire, rope and hose
- Turns reel handling into a one person operation
- Accommodates unlimited reel widths and all reel diameters, flanges up to 5 1/2" thick
- Rear roller adjusts to six positions
- Heavy-duty side rollers eliminate slipping or wedging between rollers and reel
- Inclined ramp permits easy loading and unloading
- Dimensions: 28" L x 9" W x 4 1/4" H
- Capacity: 3000 lbs in pairs
- Weight: 58 lbs/pair
- Must be anchored to floor
- Durable Kleton blue enamel finish

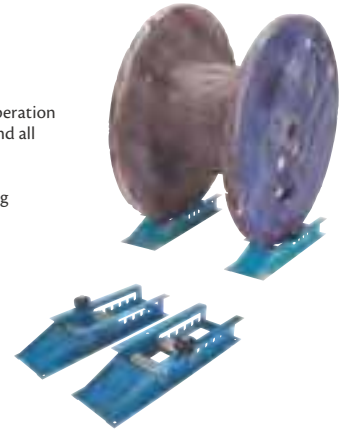

Model No. MD166



WINCH-OPERATED EASY-LIFTS

- Ideal for use in factory, office or shipping department
- Can perform numerous functions from lifting objects and positioning production at best working height, to moving light loads without tying up heavy equipment
- Manoeuvres easily in areas too narrow for a lift truck
- Two swivel casters under forks allow the shop lifter to do a 360° turn on twice the length of the base



SPECIFICATIONS:

Capacity:500 lbs. at 10" load centre
 Overall height:60"
 Platform size:20" x 20"
 Lowered platform height:4 1/2"
 Lift above floor:52"
 Wheels:6" diameter
 Swivel Casters:3" diameter
 Weight:98 lbs.

Model No. MA479

HYDRAULIC STACKERS

- Allows workers to manoeuvre and lift heavy loads safely to comfortable needed height
- Front 5" and rear 4" phenolic casters allow loads to be moved easily
- Stacker comes standard with floor locks, safety screen and foot guards for safety



SPECIFICATIONS:

Capacity:1000 lbs. at 15" load center
 Overall dimensions:25.5" W x 40" D x 80" H
 Platform size:24" x 24"
 Lowered platform height:5 3/4"
 Raised platform height:68"
 Base legs:15" inner, 21" outer
 Wheels:5" front, 4" rear
 Weight:234 lbs.

Model No. MH690

HYDRAULIC STACKER

- Allow workers to manoeuvre and lift heavy loads safely to comfortable needed height
- Foot pedal folds safely out of the way
- Front 5" polyurethane casters and rear 3" polyurethane wheels allow loads to move easily



SPECIFICATIONS:

Capacity:880 lbs.
 Overall dimensions:22 1/2" W x 39" D x 67 3/4" H
 Platform dimensions:25 3/4" L x 22 3/4" W
 Lowered platform height:4"
 Raised platform height:60"
 Weight:174 lbs.

Model No. MN397

LIFTING EQUIPMENT & DOLLIES

HYDRAULIC STACKERS

- Rugged frame construction
- Solid steel adjustable forks
- Designed for pallet loading and removal from racking storage even in the smallest storage spaces
- Straddle length: 42"
- Fork length: 42"
- Load centre: 24"
- Manually propelled with electric powered hydraulic lift
- Battery-powered is standard (AC power available)
- Automatic built-in battery charger included
- Other capacities available

PLEASE SPECIFY WHEN ORDERING:

Single stage stacker between 38" and 50"

Telescopic stacker between 42" and 54"

Note: Inside straddle dimension is recommended to be 2" greater than the overall pallet width (outside straddle is 6" greater than straddle inside dimension).

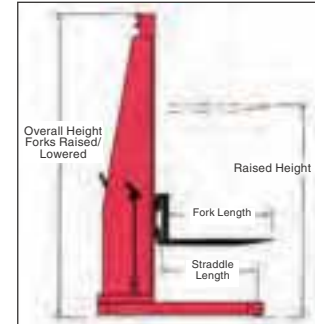
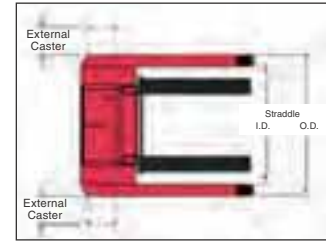

SINGLE STAGE STACKERS

| Model No. | Clearance of Top Mast" | Raised Height of Top Forks" | Capacity lbs. | Wt. lbs. |
|-----------|------------------------|-----------------------------|---------------|----------|
| LT395 | 72 | 60 | 1500 | 625 |
| LT396 | 82 | 70 | 1500 | 638 |
| LT397 | 92 | 80 | 1500 | 652 |

Other dimensions and capacities available

TELESCOPIC (TWO STAGE) STACKERS

| Model No. | Clearance of Top Mast" | Raised Height of Top Forks" | Capacity lbs. | Wt. lbs. |
|-----------|------------------------|-----------------------------|---------------|----------|
| LT398 | 70 | 96 | 1500 | 815 |
| LT399 | 82 | 120 | 1500 | 875 |
| LT400 | 88 | 132 | 1500 | 900 |
| LT401 | 94 | 144 | 1500 | 924 |

Other dimensions and capacities available

PALLET CAROUSELS

Loading and unloading operations that originally required a large amount of time can be done more efficiently with less fatigue and risk of back injury. The carousel may be added to an existing workbench, scissors table or simply placed on the floor. This Lazy Susan concept is constructed from two pieces of rolled structural angle. A series of roller bearings transfer the load smoothly and evenly to the supporting surface. Overall height is 2".

| Model No. | Outside Diameter" | Capacity lbs. | Wt. lbs. |
|-----------|-------------------|---------------|----------|
| MH204 | 40 | 2000 | 43 |
| MH205 | 40 | 4000 | 47 |
| MH206 | 40 | 6000 | 47 |

| Model No. | Outside Diameter" | Capacity lbs. | Wt. lbs. |
|-----------|-------------------|---------------|----------|
| MH207 | 48 | 2000 | 51 |
| MH208 | 48 | 4000 | 57 |
| MH209 | 48 | 6000 | 69 |



PRY DOLLIES

- Move heavy boxes, die blocks and machinery
- Heavy-duty nose plate gets under the load, 6' steel or wooden handle gives tremendous leverage
- Come with 5" x 2" poly-on-steel casters
- Use in pairs to move large objects without the need of a separate dolly

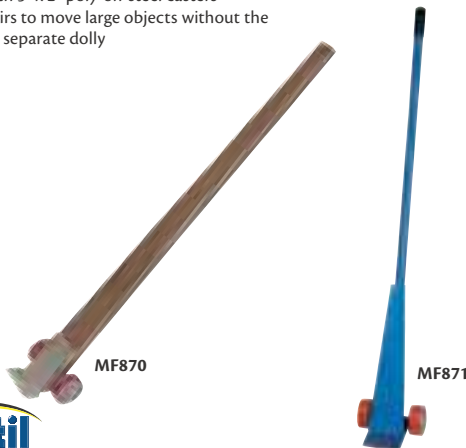

| Model No. | Handle | Nose Plate" | Cap. lbs. | Wt. lbs. |
|-----------|--------|-------------|-----------|----------|
| MF870 | Wood | 6 x 3 1/8 | 4250 | 32 |
| MF871 | Steel | 6 x 3 1/2 | 5000 | 42 |

ALUMINUM DECK DOLLIES

- 3/8" aluminum treadplate construction, countersunk bolts
- Four bolted-on 4" swivel non-marking rubber casters
- Capacity: 1200 lbs. evenly distributed



| Model No. | Dimensions W" x D" | Wt. lbs. |
|-----------|--------------------|----------|
| MA196 | 18 x 18 | 25 |
| MA197 | 18 x 24 | 27 |
| MA198 | 24 x 24 | 30 |

MACHINERY MOVERS & ROLLERS

LIGHT-DUTY SERIES ROLLERS

- Featuring an endless chain action design and comes in either rigid or swivel tops
- Both versions available topped with rough, rugged non-slip pads or smooth top style, ideal for permanent mounting applications
- Light duty series rollers are low and have high capacity



MA825



| Model No. | Cap. Tons | Top Style | Dimensions | | | Wt. lbs. |
|-----------|-----------|---------------|------------|---------|-----------|----------|
| | | | L" | x W" | x H" | |
| MA802 | 3/4 | Swivel Padded | 6 1/2 | x 3 5/8 | x 3 5/16 | 9 |
| MA825 | 2 | Swivel Padded | 6 1/2 | x 4 1/8 | x 3 15/16 | 15 |
| MD551 | 3/4 | Swivel Smooth | 6 1/2 | x 3 5/8 | x 3 | 9 |
| MD552 | 2 | Swivel Smooth | 6 1/2 | x 4 1/8 | x 3 9/16 | 15 |
| MA801 | 3/4 | Rigid Padded | 6 1/2 | x 3 5/8 | x 3 | 9 |
| MA824 | 2 | Rigid Padded | 6 1/2 | x 4 1/8 | x 3 9/16 | 15 |

LIGHT-DUTY RIGGER KITS

3 TONS TO 8 TONS

- Kits contain two steering handles and four padded rollers offered with four swivel tops or two swivel and two rigid tops
- Sturdy steel carrying case stores all items and measures 16" L x 12 3/8" W x 4 3/8" D
- Handles knock down to fit in case



| Model No. | Capacity Tons | Kit Contents | Wt. lbs. |
|-----------|---------------|---------------------------------------|----------|
| MA879 | 3 | 4 x MA802 Swivel Top | 55 |
| MA875 | 3 | 2 x MA802 Swivel, 2 x MA801 Rigid Top | 43 |
| MA887 | 8 | 4 x MA825 Swivel Top | 85 |
| MA876 | 8 | 2 x MA825 Swivel, 2 x MA824 Rigid Top | 83 |

TOE JACKS

- Strong, portable and safe
- Lifts loads with only 1" ground clearance
- 5 and 10-ton models operate horizontally and vertically
- Base, toe and pump assembly swivel independently of each other
- Perfect complement to any Hilman roller



| Model No. | Max Lifting Height | Pick-Up Position At Base | Capacity Tons | Wt. lbs. |
|-----------|--------------------|--------------------------|---------------|----------|
| MH825 | 8.24 | 1.06 | 5 | 44 |
| MH826 | 9.32 | 1.06 | 10 | 64 |
| MH827 | 9.32 | 2.16 | 25 | 203 |

DELUXE KITS

15 TONS TO 60 TONS

- Rugged kits are preferred by many professional riggers and movers
- Use them at the job site, in the factory, to solve your heavy load moving problems
- Steel chain-action rollers are perfect for machinery and equipment moves and convenient to have in every tool crib
- Kits include four locking rollers with either padded or diamond steel tops and two steering handles (four preload pads are included with diamond top kits)
- Kit cases are lockable and have sturdy lifting grips for easy handling

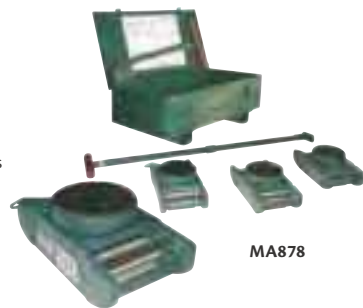

MA878



| Model No. | Capacity Tons | Kit Contents | Wt. lbs. |
|-----------|---------------|--|----------|
| MA878 | 15 | 4 x MA839 Padded Tops | 196 |
| MA877 | 15 | 4 x MA838 Diamonds, 4 x Preload Pad Tops | 196 |
| MA881 | 30 | 4 x MA863 Padded Tops | 208 |
| MA880 | 30 | 4 x MA862 Diamonds, 4 x Preload Pad Tops | 208 |
| MA883 | 40 | 4 x MA805 Padded Tops | 212 |
| MA882 | 40 | 4 x MA804 Diamonds, 4 x Preload Pad Tops | 212 |
| MA885 | 60 | 4 x MA812 Padded Tops | 248 |
| MA884 | 60 | 4 x MA811 Diamonds, 4 x Preload Pad Tops | 252 |

TRI-GLIDE 3-POINT MOVING SYSTEMS

6 TONS TO 18 TONS

- Tri-Glide 3-point moving system is designed for moving heavy loads over specially coated floors
- Comprised of a front steering unit and two rear adjustable units
- Additional modules can be added to further stabilize large, bulky loads
- Developed in response to a growing demand for floor protection when moving heavy loads over smooth, painted, finished, or sealed floors



| Model No. | Cap. Tons | Roll Material | Dimensions Front Unit | | | Rear Unit Width Adj." | Wt lbs. |
|-----------|-----------|---------------|-----------------------|----------|------|-----------------------|---------|
| | | | L" | x W" | x H" | | |
| MH768 | 6 | Nylon | 21 1/16 | x 18 1/2 | x 4 | 10-48 | 186 |
| MH769 | 12 | Nylon | 23 1/8 | x 18 1/2 | x 4 | 14-48 | 215 |
| MH770 | 18 | Nylon | 25 5/8 | x 18 1/2 | x 4 | 19-48 | 24 |

BOLT-ON ROLLERS

- Oversized tops enable them to be bolted or welded to heavy load
- Work equally well upside down or right side up
- Ideal for applications requiring permanent or semi-permanent mounting (linear motion, bearing slides, heavy casters, or conveyors)



| Model No. | Capacity Tons | Dimensions | | | Wt. lbs. |
|-----------|---------------|------------|------|---------|----------|
| | | L" | x W" | x H" | |
| MA800 | 3/4 | 6 1/2 | x 7 | x 3 1/4 | 12 |
| MA826 | 2 1/2 | 6 1/2 | x 7 | x 3 5/8 | 21 |
| MA850 | 5 | 8 | x 8 | x 3 1/8 | 22 |
| MA810 | 15 | 10 5/8 | x 10 | x 3 7/8 | 46 |
| MA827 | 20 | 10 5/8 | x 10 | x 3 7/8 | 49 |
| MA849 | 37 1/2 | 15 | x 12 | x 5 1/2 | 121 |
| MA867 | 75 | 21 | x 14 | x 6 3/4 | 241 |

MOVING SUPPLIES

POLYETHYLENE TARPULINS

- Reinforced polypropylene rope sewn-in welded hems
- Heavy-duty rust resistant grommets every 3'
- Increased UV resistance for long life
- Water resistant coating
- Finished sizes may vary due to hem allowance

NI771

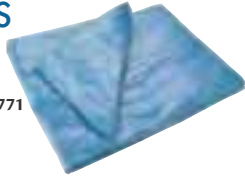

STANDARD-DUTY BLUE

- 8 x 8 weave density
- 100-micrometres thick (4 mil)



Reinforced Corner

NI783
Heavy-Duty White

HEAVY-DUTY WHITE

- 10 x 10 weave density
- 150-micrometres thick (6 mil)
- Four corner patches



3-Layer Corner

JB567

INDUSTRIAL GREEN/SILVER

- 14 x 14 high density weave
- 225-micrometres thick (9 mil)
- 9" x 9" triple layered on four corners

SUPER HEAVY-DUTY SILVER

- 16 x 16 high density weave
- 300-micrometres thick (12 mil)
- 9" x 9" triple layered on four corners
- Silver side provides heat and UV light diversion



JC626



| Dimensions' | Model No. | | | |
|-------------|--------------------|------------------|-------------------------|-------------------------|
| | Standard-Duty Blue | Heavy-Duty White | Industrial Green/Silver | Super Heavy-Duty Silver |
| 5 x 7 | NI768 | - | - | - |
| 6 x 8 | NI769 | NI780 | JB567 | - |
| 8 x 10 | NI770 | NI781 | JB568 | JC626 |
| 10 x 12 | NI771 | NI782 | JB569 | JC627 |
| 10 x 20 | NI772 | - | - | - |
| 12 x 16 | NI773 | NI783 | JB570 | - |
| 16 x 20 | NI774 | NI784 | JB571 | JC628 |
| 18 x 24 | NI775 | JC512 | - | JC629 |
| 20 x 30 | NI776 | JC513 | JB572 | JC630 |
| 24 x 30 | NI777 | NI785 | - | JC631 |
| 30 x 40 | NI778 | JC514 | JC516 | JC632 |
| 30 x 50 | JC510 | JC515 | JC517 | JC633 |
| 30 x 60 | - | - | - | JC634 |
| 40 x 50 | JC511 | JC625 | JC518 | - |
| 40 x 60 | NI779 | JB508 | JB573 | JC635 |

INSULATED TARPULINS

- Lightweight and flexible, moisture resistant insulated tarpaulin
- Manufactured with 3/16" closed cell polyethylene foam insulation
- R-value is maintained in damp cold conditions
- Durable, water resistant polyethylene shell
- Heavy-duty rust resistant grommets every 2'
- R value: 1.0
- Dimensions: 12' x 20'

Model No. JD420

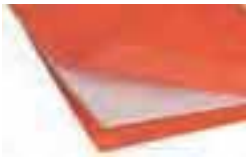

CLEAR TARPULINS

- Polyethylene tarpaulin with reinforced nylon gridding
- Water and mildew resistant coating
- Heavy-duty rust resistant grommets
- 3 x 3 weave density
- 200 micrometers (8-mil) thick
- Finished sizes may vary due to hem allowance



| Model No. | Dimensions' |
|-----------|-------------|
| JD414 | 8 x 10 |
| JD415 | 10 x 12 |
| JD416 | 16 x 20 |
| JD417 | 20 x 30 |
| JD418 | 30 x 40 |
| JD419 | 40 x 60 |

FURNITURE PADS

- Protect furniture from scratches when moving
- Zigzag stitching provides durability and consistent cushioning
- Cotton and polyester material
- 72" W x 80" L

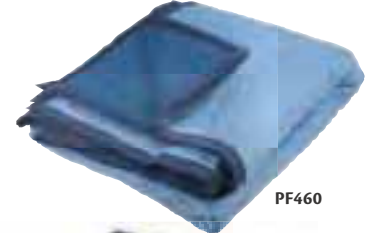

PF460

PREMIUM FURNITURE PADS

- 40-oz. filling
- Dark blue/light blue
- Weight: 5.5 lbs.

Model No. PF460

STANDARD FURNITURE PADS

- 29-oz. filling
- Dark blue/green
- Weight: 5 lbs.

Model No. PF461



PF461

STRAP-ALL™ ONE INCH STRAPS

- Ratchet strap with ratchet
- Light-duty tie-down can be used on pick-up trucks utility trailers, car top racks and boat trailers



| Model No. | Strap Length' | Breaking Strength lbs. | Working Load Limit lbs./kg |
|-----------|---------------|------------------------|----------------------------|
| ND361 | 16 | 1200 | 835/380 |

2" LOGISTIC STRAPS

- Designed to take care of most interior van loading requirements
- Standard 48" fixed end
- Adjustable captive end to avoid loss or theft
- Comes with ratchet buckle and webbing
- Spring-loaded "E"



ND352



| Model No. | Strap Length' | Strap Width" | Breaking Strength lbs. | Colour | Working Load Limit lbs./kg |
|-----------|---------------|--------------|------------------------|--------|----------------------------|
| ND352 | 12 | 2 | 3000 | Gold | 1000/455 |
| ND353 | 16 | 2 | 3000 | Grey | 1000/455 |
| ND354 | 20 | 2 | 3000 | Blue | 1000/455 |

RUBBER TIE DOWNS

- Retains its rebound qualities
- Rot resistant
- Zinc-plated steel hooks

| Model No. | Length" | Model No. | Length" |
|-----------|---------|-----------|---------|
| PE366 | 5 | PE369 | 21 |
| PE367 | 9 | PE370 | 31 |
| PE368 | 15 | PE371 | 41 |



10-PC. BASIC TIE DOWN SET

Model No. PF090 Set contains: 4 PE369, 2 PE370 and 4 PE371

16-PC. ALL-PURPOSE TIE DOWN SET

Model No. PF091 Set contains: 2 PE367, 2 PE368, 4 PE369, 4 PE370 and 4 PE371

20-PC. PROFESSIONAL TIE DOWN SET

Model No. PF092 Set contains: 10 PE369 and 10 PE371



HARDWOOD DOLLIES

- Kiln dried
- Countersunk bolts prevent scratches
- Wood thickness: 7/8"
- Rounded edges and handles facilitate storage and movability
- Non-marking casters
- Shipped knocked down



MN204



MN217



MN200

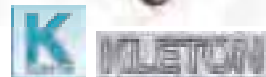

REPLACEMENT CASTERS

| Model No. | Description |
|-----------|-------------------------------|
| ML391 | 3" Swivel Polyolefin |
| ML044 | 3" Swivel Polyurethane |
| ML393 | 4" Swivel Polyolefin |
| ML333 | 4" Swivel Blue Elastic Rubber |
| ML045 | 4" Swivel Polyurethane |

CHOOSE FROM THREE CASTER TYPES



| Model No. | Dimensions W" x D" | Caster Type | Caster" | Capacity lbs.* |
|----------------------|--------------------|--------------|---------|----------------|
| ALL WOOD | | | | |
| MN189 | 18 x 24 | Polyolefin | 3 | 900 |
| MN195 | 18 x 24 | Polyurethane | 3 | 900 |
| MN201 | 18 x 24 | Polyolefin | 4 | 1000 |
| MN213 | 18 x 24 | Blue Elastic | 4 | 1400 |
| MN207 | 18 x 24 | Polyurethane | 4 | 1600 |
| MN192 | 18 x 30 | Polyolefin | 3 | 900 |
| MN198 | 18 x 30 | Polyurethane | 3 | 900 |
| MN204 | 18 x 30 | Polyolefin | 4 | 1000 |
| MN216 | 18 x 30 | Blue Elastic | 4 | 1400 |
| MN210 | 18 x 30 | Polyurethane | 4 | 1600 |
| CARPETED ENDS | | | | |
| MN190 | 18 x 24 | Polyolefin | 3 | 900 |
| MN196 | 18 x 24 | Polyurethane | 3 | 900 |
| MN202 | 18 x 24 | Polyolefin | 4 | 1000 |
| MN214 | 18 x 24 | Blue Elastic | 4 | 1400 |
| MN208 | 18 x 24 | Polyurethane | 4 | 1600 |
| MN193 | 18 x 30 | Polyolefin | 3 | 900 |
| MN199 | 18 x 30 | Polyurethane | 3 | 900 |
| MN205 | 18 x 30 | Polyolefin | 4 | 1000 |
| MN217 | 18 x 30 | Blue Elastic | 4 | 1400 |
| MN211 | 18 x 30 | Polyurethane | 4 | 1600 |
| RUBBER ENDS | | | | |
| MN191 | 18 x 24 | Polyolefin | 3 | 900 |
| MN197 | 18 x 24 | Polyurethane | 3 | 900 |
| MN203 | 18 x 24 | Polyolefin | 4 | 1000 |
| MN215 | 18 x 24 | Blue Elastic | 4 | 1400 |
| MN209 | 18 x 24 | Polyurethane | 4 | 1600 |
| MN194 | 18 x 30 | Polyolefin | 3 | 900 |
| MN200 | 18 x 30 | Polyurethane | 3 | 900 |
| MN206 | 18 x 30 | Polyolefin | 4 | 1000 |
| MN218 | 18 x 30 | Blue Elastic | 4 | 1400 |
| MN212 | 18 x 30 | Polyurethane | 4 | 1600 |

* Evenly distributed

WOOD DOLLY RACKS

- Convert a basic wood dolly into a multi-purpose panel caddy
- All-welded 1" tube design for durability
- Tubular steel rack is padded to prevent scratching or marring
- Durable Kleton blue enamel finish



Wood dolly not included

| Model No. | Description | Wt. lbs. |
|-----------|-------------------------------|----------|
| MD549 | Use with Wood Dolly 18" x 24" | 12 |
| MD550 | Use with Wood Dolly 18" x 30" | 15 |

STEEL DECK DOLLIES

- Heavy-duty, all-welded 14-gauge steel deck
- Four bolted-on 4" swivel non-marking rubber casters
- MA199 - Optional 34" long steel T-handle for ease of movement under full loads
- Capacity: 1200 lbs. evenly distributed
- Caster assembly required
- Durable Kleton blue enamel finish

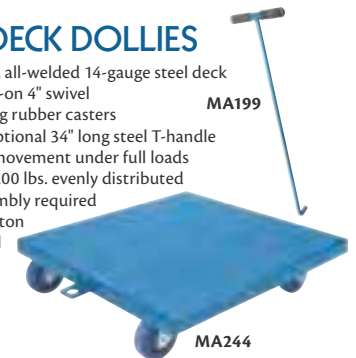

| Model No. | Dimensions W" x D" x H" | Wt. lbs. |
|-----------|-------------------------|----------|
| MA242 | 18 x 18 x 7 | 23 |
| MA243 | 18 x 24 x 7 | 25 |
| MA244 | 24 x 24 x 7 | 27 |
| MA199 | 34" Handle | 2 |

ANGLE FRAME DOLLIES

- Heavy-duty all-welded 1 1/2" x 1 1/2" x 1/8" angle frame construction
- Four bolted-on 4" swivel non-marking rubber casters
- Capacity: 1200 lbs. evenly distributed
- Caster assembly required
- Durable Kleton blue enamel finish

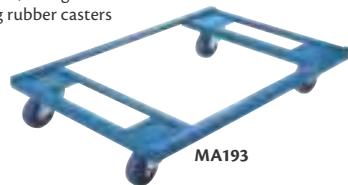

MA193



| Model No. | Dimensions W" x D" x H" | Wt. lbs. |
|-----------|-------------------------|----------|
| MA190 | 18 x 18 x 7 | 23 |
| MA191 | 18 x 24 x 7 | 25 |

| Model No. | Dimensions W" x D" x H" | Wt. lbs. |
|-----------|-------------------------|----------|
| MA192 | 24 x 24 x 7 | 27 |
| MA193 | 24 x 36 x 7 | 30 |

PREMIUM HARDWOOD DOLLIES

MEDIUM-DUTY

- 7/8" wood top; countersunk bolts
- Carpeted dolly will prevent marks and scratches on equipment being moved
- 3" polyolefin casters
- Capacity: 900-lbs. evenly distributed
- Shipped knocked down

HEAVY-DUTY

- 1 3/4" wood top (2 x 1 1/16" pieces); countersunk bolts
- Carpeted dolly will prevent marks/scratches on equipment
- 4" resilient non-marking casters
- Capacity: 1400 lbs. evenly distributed
- Shipped knocked down



Medium-duty



Heavy-duty



| Model No. | Dim. W" x D" | Platform Type | Wt. lbs. |
|--------------------|--------------|---------------|----------|
| MEDIUM-DUTY | | | |
| MA186 | 18 x 24 | Standard | 26 |
| MA187 | 18 x 24 | Carpeted | 28 |
| MD515 | 18 x 30 | Standard | 32 |
| MD516 | 18 x 30 | Carpeted | 34 |

| Model No. | Dim. W" x D" | Platform Type | Wt. lbs. |
|-------------------|--------------|---------------|----------|
| HEAVY-DUTY | | | |
| MA188 | 18 x 24 | Standard | 30 |
| MA189 | 18 x 24 | Carpeted | 32 |
| MD517 | 18 x 30 | Standard | 38 |
| MD518 | 18 x 30 | Carpeted | 40 |

POLYETHYLENE DOLLIES

- Modular, high-impact polyethylene design
- Won't splinter, swell or rot
- Round corners and edges with channel steel reinforced sides
- 4" polyolefin swivel casters
- Capacity: 400 lbs.

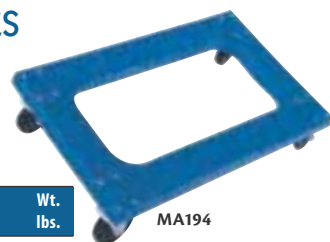

MA194

| Model No. | Dimensions W" x D" x H" | Platform Type | Wt. lbs. |
|-----------|-------------------------|--------------------|----------|
| MA194 | 18 x 30 x 6 | Flush Deck | 21 |
| MA195 | 18 x 30 x 6 | Padded Rubber Deck | 23 |



CUSTOMISE IT TO YOUR SPECIFICATIONS. SEE PAGE B71 FOR DETAILS

HAND TRUCKS

RUBBER WHEEL HAND TRUCKS

- Constructed of 1" 16-gauge steel tube
- 7-gauge steel nose plate
- Overall width: 19 1/2"
- Wheel dimensions: 8" x 2"
- Powder coated finish



| Model No. | Description | Nose Plate Dimensions | | Overall Height" | Capacity lbs. | Wt. lbs. |
|-----------|-------------------|-----------------------|---------|-----------------|---------------|----------|
| | | W" | x D" | | | |
| MK728 | Continuous Handle | 14 | x 8 1/2 | 46 | 600 | 24 |
| MK729 | Dual Handle | 14 | x 8 1/2 | 48 | 600 | 24 |
| MN103 | P-Handle | 14 | x 9 | 51 | 600 | 24 |

REPLACEMENT PARTS & WHEELS

| Model No. | Description |
|-----------|--------------|
| ML812 | Rubber Wheel |
| MK993 | Hand Grip |



MK729

MK728

MN103

PNEUMATIC WHEEL HAND TRUCKS

- Constructed of 1" 16-gauge steel tube
- 8-gauge steel nose plate
- Overall width: 21 1/2"
- Wheel dimensions: 10" x 3"
- Powder coated finish



| Model No. | Description | Nose Plate Dimensions | | Overall Height" | Capacity lbs. | Wt. lbs. |
|-----------|-------------------|-----------------------|------|-----------------|---------------|----------|
| | | W" | x D" | | | |
| MH300 | Dual Handle | 14 | x 10 | 46 | 600 | 23 |
| MH301 | Continuous Handle | 14 | x 10 | 48 | 600 | 26 |
| MH302 | P-Handle | 14 | x 9 | 51 | 600 | 23 |

REPLACEMENT PARTS & WHEELS

| Model No. | Description |
|-----------|-----------------|
| ML810 | Pneumatic Wheel |
| MK993 | Hand Grip |



MH301

MH300

MH302

FLAT FREE WHEEL HAND TRUCKS

- Constructed of 1", 16-gauge steel tubing
- Nose plate 8-gauge steel
- Overall width: 22"
- Wheel dimensions: 10" x 3 1/2"
- Powder-coated



| Model No. | Description | Nose Plate Dimensions | | Overall Height" | Capacity lbs. | Wt. lbs. |
|-----------|-------------------|-----------------------|------|-----------------|---------------|----------|
| | | W" | x D" | | | |
| MN389 | Dual Handle | 14 | x 10 | 46 | 600 | 20 |
| MN390 | Continuous Handle | 14 | x 10 | 48 | 600 | 22 |
| MN391 | P-Handle | 14 | x 9 | 51 | 600 | 22 |

REPLACEMENT PARTS & WHEELS

| Model No. | Description |
|-----------|-----------------|
| MN378 | Flat Free Wheel |
| MK993 | Hand Grip |



MN389

MN390

MN391

HEAVY-DUTY DUAL HANDLE HAND TRUCKS

- Constructed of 1 1/4" 14-gauge steel tube
- 6-gauge steel nose plate
- Overall height: 46"
- Overall width: 20"
- Powder coated finish



| Model No. | Description | Wheel Dimensions" | Nose Plate Dimensions | | Capacity lbs. | Wt. lbs. | |
|-----------|-----------------|-------------------|-----------------------|------|---------------|----------|----|
| | | | W" | x D" | | | |
| MK731 | Pneumatic Wheel | 10 | x 3 | 14 | x 8 | 800 | 36 |
| MK730 | Rubber Wheel | 8 | x 2 | 14 | x 8 | 1000 | 36 |

REPLACEMENT PARTS & WHEELS

| Model No. | Description |
|-----------|-----------------|
| ML813 | Rubber Wheel |
| ML811 | Pneumatic Wheel |
| ML030 | Hand Grip |



MK730

MK731

HEAVY-DUTY SPADE TRUCKS

- All welded, ready to use
- Constructed of double-welded 1 1/4" round 14-gauge steel tubing
- Oversized nose plate and easy grip frame helps with the balancing of larger items
- Tapered 22" L x 13" D x 1/4" thick nose plate
- Two 10" mold-on rubber wheels
- Capacity: 1200 lbs.
- Durable Kleton blue enamel finish



| Model No | Dimensions W" x H" | Wt. lbs. |
|----------|--------------------|----------|
| ML324 | 22" x 53" | 92 |



APPLIANCE TRUCKS

- Move large appliances easily
- Heavy-duty all welded industrial construction
- Vinyl bumpers on face of truck to prevent damage to appliances
- Heavy-duty continuous stair climbers for easy climbing/descending
- 8" solid rubber wheels
- Ratchet mechanism for easy fastening of loads
- Overall dimensions: 14 1/2" L x 24" W x 59" H
- Capacity: 550 lbs.
- Weight: 46 lbs.

Model No. ML616



VENDING MACHINE APPLIANCE TRUCKS

- Move large appliances easily
- Heavy-duty all welded industrial construction
- Vinyl bumpers on face of truck to prevent damage to appliances
- Heavy-duty continuous stair climbers for easy climbing/descending
- Fold out rear legs with two 4" swivel casters
- 8" solid rubber front wheels
- Ratchet mechanism for easy fastening of loads
- Overall dimensions: 14 1/2" L x 24" W x 66" H
- Capacity: 850 lbs.
- Weight: 65 lbs.

Model No. ML617



MOVING STRAPS

- Allows for safe movement of appliances and larger items
- Movers can constantly stay in an upright position during the move, reducing the risk of back injuries
- Nylon (5000 lbs. test)
- **Includes:** Two transport straps, 4' x 4', and two adjustable straps, 1 3/4" x 9'

Model No. MD223



HEAVY-DUTY DUAL HANDLE HAND TRUCKS

- Constructed of 1 1/4", 14-gauge steel tubing
- Nose plate 6-gauge steel
- Overall height: 46"
- Overall width: 20"
- 8" x 12" nose plate
- Powder-coated



| Model No. | Description | Wheel" | Capacity lbs. | Wt. lbs. |
|-----------|--------------|--------|---------------|----------|
| MA376 | Rubber Wheel | 10 x 2 | 1000 | 40 |



DELUXE 12" NOSE PLATE HAND TRUCKS

- All welded, ready to use
- Constructed of 1" round 14-gauge steel tubing
- Transport short to tall loads easily
- P handle ideal for one hand control
- Strong 12" L x 14" D x 3/16" thick nose plate
- Double welded 3/16" x 1 1/2" cross bars
- Add a folding nose extension to be able to transport larger loads
- Two 10" full pneumatic wheels
- Capacity: 700 lbs.
- Durable Kleton blue enamel finish

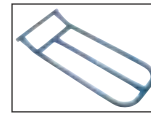

ML323
Nose Extension

ML321



ML322



| Model No | Description | Overall Dimensions W" x H" | Wt. lbs. |
|----------|----------------|----------------------------|----------|
| ML321 | Lo-Boy | 23 x 50 | 40 |
| ML322 | Hi-Boy | 23 x 72 | 46 |
| ML323 | Nose Extension | 12x22" Nose Length | 8 |

CONVERTIBLE DELUXE STEEL HAND TRUCKS

- Constructed of 1" round 14-gauge steel tubing
- Quickly converts from a 2-wheel hand truck to a 4-wheel platform truck
- 8" x 14" nose plate
- Comes with two welded-on stair glides
- Two 10" full pneumatic wheels and two 3" bolted-on casters
- Capacity: Hand truck 600 lbs.
Platform truck 800 lbs.
- Durable Kleton blue enamel finish



| Model No | Overall Dimensions W" x D" x H" | Wt. lbs. |
|----------|---------------------------------|----------|
| ML320 | 14 x 43 x 46 | 75 |



HAND TRUCKS WITH SWIVEL CASTERS

- 4" rear poly casters allow small diameter turns in tight areas
- Combination two handle and utility bar design reduces strain of lifting, lowering and transporting
- 8" deep nose plate
- 10" x 2 3/4" semi-pneumatic front wheels
- Overall dimensions: 20 1/2" W x 47 1/2" H
- Capacity: 800 lbs.
- Weight: 53 lbs.

Model No. MD758



HAND TRUCKS

NYLON FRAME HAND TRUCKS

STRONG AS STEEL, LIGHTER THAN ALUMINUM

- Long fibre nylon frame will not mar products or damage goods
- Stair glides integrate into frame
- Aluminum loop handles, 14" W x 8" D nose plate
- Frame width: 12"
- Capacity: 500 lbs.



Loop Handle

MN269



| Model No. | Wheel Type | O.A. Height" | Wt. lbs. |
|---------------------------|---------------|--------------|----------|
| FLAT BACK FRAME | | | |
| MN268 | 10" Rubber | 52 | 21 |
| MN269 | 10" Pneumatic | 52 | 19 |
| CURVED BACK FRAME* | | | |
| MN270 | 10" Rubber | 52 | 21 |
| MN271 | 10" Pneumatic | 52 | 19 |

*Handles cylindrical or flat beds

NYLON LITE HAND TRUCKS

- Lighter than aluminum trucks
- Glass-filled nylon frame will not mark products or damage goods
- Steel handle, 14" W x 7" D steel base plate
- 10" x 3 1/2" pneumatic tires
- Frame width: 12"
- Overall height: 48"
- Capacity: 500 lbs.
- Weight: 22 lbs.

Model No. MD642



CONVERTIBLE NYLON LITE TRUCKS

- Lighter than equivalent aluminum trucks
- Glass-filled nylon frame
- Steel handle and 14 1/2" W x 7" D steel base plate
- Converts in seconds from 2-wheel hand truck to 4-wheel platform truck
- 5" swivel casters, 10" x 3 1/2" pneumatic wheels
- 12" frame width and 20 1/2" overall width
- Capacity: 600 lbs., two wheels; 700 lbs., four wheels



| Model No. | Hand Truck | | Platform/Truck | | Wt. lbs. |
|-----------|------------|---------|----------------|---------|----------|
| | Cap. lbs. | Height" | Length | Height" | |
| MD643 | 600 | 49 1/2 | 40 | 36 | 25 |

CURB RAMP

- Light, portable and easy to handle
- Dimensions: 27" x 27"
- Capacity: 600 lbs.

Model No. MH224



LOAD RETENTION HAND TRUCKS

- Constructed of 1" round 14-gauge steel tubing
- 18 1/2" x 53" load retention grill to safely handle wide and awkward loads
- 7-gauge steel nose plate
- 18 1/2" W x 9 3/4" D nose plate
- Two 10" full pneumatic wheels
- Capacity: 600 lbs.
- Durable Kleton blue enamel finish

Model No. MN412



FOLDING HAND TRUCKS

- Lightweight and durable aluminum construction
- Convenient folding design permits storage in small spaces
- Comfortable ergonomic handle
- Elastic straps help to secure load
- Non-marking and shock-absorbing rubber wheels
- Capacity: 175 lbs. evenly distributed
- Weight: 8.75 lbs.



| Model No. | Extended Dimensions" | Folded Dimensions" | Nose Plate W" x D" | Wheel Dimensions" |
|-----------|--------------------------|--------------------|--------------------|-------------------|
| ML447 | 39 5/8 x 15 1/2 x 16 1/2 | 25 x 15 x 2 3/8 | 15 1/4 x 11 | 5 x 1 1/4 |

ALUMINUM STAIR CLIMBING HAND TRUCKS

- Battery-powered stair climbing hand trucks help reduce worker fatigue and the risk of injury, as well as reduce the number of employees needed to deliver cargo
- Pivoting and fixed ergonomic handle configurations available to handle a wide variety of cargo
- Lift wheels are uni-directional to help prevent cargo from accidentally rolling down the stairs
- Dual speed control on all models to fit your application
- Electronic overload protection protects operating components if capacity is exceeded
- Grooved 16 1/2" W x 13 1/3" D nose plate provides superior grip to hold load in place
- 10" pneumatic wheels
- Capacity: 375 lbs.
- Quick-change battery and charger included



MN247

MN248

MN249

MN250

| Model No. | Frame Type | Dimensions | | |
|-----------|------------|------------|---|--------------------|
| | | W" | x | H" |
| MN247 | Ergo | 18 1/2 | x | 63 |
| MN248 | Fold | 18 | x | 61 (40 Folded) |
| MN249 | Uni | 17 1/2 | x | 59 |
| MN250 | Fold-L | 19 | x | 64 1/2 (51 Folded) |

Note: Each unit is capable of being customized with various options (i.e. wheel type and nose plate size). Also available in 240-lb. and 300-lb. capacities.

ALUMINUM HAND TRUCKS

CONVERTIBLE HAND TRUCKS

- Lightweight aluminum construction
- Converts easily from a 2-wheel hand truck to a 4-wheel platform truck
- 5" polyurethane casters and 10" flat free wheels
- Shipped assembled



| Model No. | Nose Plate | Hand Truck | | Platform Truck | | Wt. lbs. |
|-----------|------------|------------|---------|----------------|---------|----------|
| | W" x D" | Cap. lbs. | Height" | Cap. lbs. | L" x W" | |
| ML621 | 18 x 10 | 600 | 52 | 1250 | 12 x 43 | 54 |



ALUMINUM HAND TRUCKS

- Strong lightweight hand truck provides exceptional durability and versatility
- Weld-free design for easy maintenance
- Capacity: 500 lbs.
- Shipped knocked down



| Model No. | Nose Plate W" x D" | Overall Height" | Wheels | Wt. lbs. |
|-----------|--------------------|-----------------|---------------|----------|
| A. MN024 | 14 x 7 1/2 | 48 | 8" Mold-On | 17.5 |
| B. MN025 | 18 x 7 1/2 | 48 | 8" Mold-On | 20.5 |
| C. MN026 | 14 x 7 1/2 | 52 | 10" Pneumatic | 21.5 |
| D. MN027 | 18 x 7 1/2 | 48 | 8" Mold-On | 20 |
| E. MN028 | 18 x 7 1/2 | 52 | 10" Pneumatic | 23 |
| E. MN029 | 18 x 7 1/2 | 52 | 10" Flat-Free | 20 |
| F. MN030 | 14 x 7 1/2 | 52 | 10" Pneumatic | 22 |
| G. MN031 | 18 x 10 | 52 | 10" Pneumatic | 26.5 |
| G. MN032 | 18 x 10 | 52 | 10" Flat-Free | 23 |
| H. MN033 | 18 x 7 1/2 | 52 | 10" Pneumatic | 23.5 |
| I. MN034 | 14 x 7 1/2 | 48 | 10" Flat-Free | 20 |

HAND TRUCK ACCESSORIES



FRAME EXTENSIONS



• Size: 17"

Model No. MN021

• Size: 23"

Model No. MN022

STAIR CLIMBERS

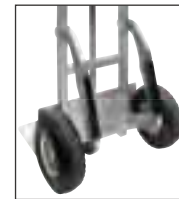

Model No. MN015

NOSE EXTENSIONS

- Only compatible with cast nose plates

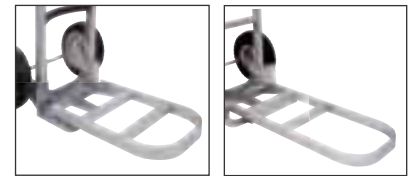

• Size: 20"

Model No. MN019

• Size: 27"

Model No. MN020

REPLACEMENT WHEELS



• 10" Pneumatic
Model No. MN012

• 8" Mold-On Rubber
Model No. MN013

• 10" Flat-Free
Model No. MN014

ALUMINUM HAND TRUCKS

BUILD YOUR OWN HAND TRUCK IN 4 EASY STEPS



STEP 1: SELECT YOUR HANDLE



• Standard loop with rubber sleeve
Model No. ML997



• Standard loop
Model No. ML998



• Vertical loop
• Not for use with MN006 and MN007
Model No. ML999



• Double grip
Model No. MN001



• Single grip
Model No. MN002



• Double "P"
Model No. MN003

STEP 2: SELECT YOUR FRAME



• Straight frame
Model No. MN004



• Straight frame with large cross bar
Model No. MN005



• Curved back frame
Model No. MN006

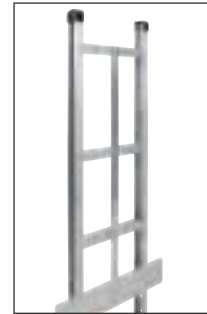

• Lattice back frame
Model No. MN007



MN026

STEP 3: SELECT YOUR NOSE PLATE

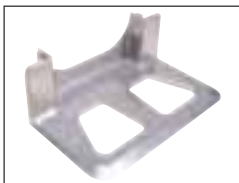

• Cast nose plate
• Dimensions: 14" x 7 1/2"
Model No. MN008

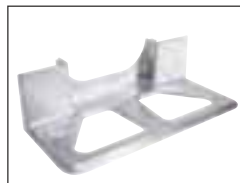

• Cast nose plate
• Dimensions: 18" x 7 1/2"
Model No. MN009



• Extrude nose plate
• Dimensions: 18" x 7 1/2"
Model No. MN010



• Extrude nose plate
• Dimensions: 18" x 10"
Model No. MN011

STEP 4: SELECT YOUR WHEEL ASSEMBLY

Assembly includes two wheels, two axle brackets and one axle



• 8" Mold-On rubber
Model No. MN035



• 10" Pneumatic
Model No. MN036



• 10" Flat-Free
Model No. MN037



MN033

ALUMINUM HAND TRUCKS

GEMINI® CONVERTIBLE ALUMINUM TRUCKS

- Converts in seconds from a 2-wheel hand truck to a 4-wheel platform truck
- Lightweight, high strength aluminum construction
- Balanced to assure easier wheeling and positive load control
- 18" W x 7 1/2" D rugged cast aluminum noseplate
- 5" swivel casters; 10" x 3 1/2" full pneumatic wheels
- 16 5/8" frame width, 20 1/2" O.A. width
- Shipped knocked down



| Model No. | Gemini | Hand Truck Cap. | Ht." | Platform Truck Cap. | Ht." | Lgth." | Wt. lbs. |
|-----------|--------|-----------------|------|---------------------|--------|--------|----------|
| MA319 | Jr. | 500 lbs. | 51 | 1000 lbs. | 40 | 38 | 44 |
| MA320 | Sr. | 500 lbs. | 61 | 1000 lbs. | 45 1/8 | 51 | 45 |

OPTIONAL SNAP-ON DECK

| Model No. | Description | Wt. lbs. |
|-----------|------------------------|----------|
| MB198 | 43 1/4" for Gemini Jr. | 5 |
| MB197 | 56" for Gemini Sr. | 6 |

Gemini Sr.
MA320



Gemini Jr.
MA319



ALUMINUM HAND TRUCKS

- Strength, durability and versatility in a lightweight truck
- Totally modular trucks have no welds to break
- 500-lb. capacity on all models
- Shipped knocked down



| Model No. | Nose Plate W" x D" | Overall Ht." | Wheels | Wt. lbs |
|-----------|--------------------|--------------|---------------|---------|
| A. MA250 | 14 x 7 1/2" | 48 | 8" Mold-On | 18 |
| B. MA269 | 18 x 7 1/2" | 48 | 8" Mold-On | 19 |
| C. MA275* | 14 x 7 1/2" | 48 | 10" Pneumatic | 21 |
| D. MA258 | 14 x 7 1/2" | 52 | 8" Mold-On | 19 |
| D. MA255 | 14 x 7 1/2" | 52 | 10" Pneumatic | 21 |
| E. MA263 | 14 x 7 1/2" | 48 | 8" Mold-On | 21 |
| E. MA261 | 14 x 7 1/2" | 48 | 10" Pneumatic | 24 |
| F. MA271 | 18 x 9" | 48 | 8" Mold-On | 19 |
| F. MA270 | 18 x 9" | 48 | 10" Pneumatic | 22 |
| G. MA266 | 18 x 7 1/2" | 52 | 8" Mold-On | 19 |
| G. MA265 | 18 x 7 1/2" | 52 | 10" Pneumatic | 22 |
| H. MA268 | 18 x 7 1/2" | 54 | 8" Mold-On | 19 |
| H. MA267 | 18 x 7 1/2" | 52 | 10" Pneumatic | 22 |

* Frame has a curved back for cylindrical or flat loads



FOLDING HAND TRUCK

- Easy-to-use latch system may be engaged with one hand
- Heavy-duty construction
- Features a comfort grip handle
- 8" mold-on rubber wheels
- 14" x 7" locking folding nose plate
- Overall height: 48"
- Capacity: 500 lbs.
- Weight: 22 lbs.

Model No. MN117



THREE-POSITION HAND TRUCK

- Can be used to transport all your needs, from general use items to bulky equipment
- 18" x 7 1/2" nose plate included
- Two 10" pneumatic wheels and two 5" polyurethane casters
- Two wheel position: 500 lbs. capacity, overall height 51"
- Four wheel position: 750 lbs. capacity, overall height 40"
- Weight: 43 lbs.

Model No. MN118



Y-CABLE BRAKE HAND TRUCK

- Provides safer load control and reduces operator's accumulated muscle strain
- Easy ergonomic self-equalizing brake actuators
- Stair climber included
- 18" x 9" nose plate
- 10" pneumatic wheels
- Overall height: 60"
- Capacity: 500 lbs.
- Weight: 38 lbs.

Model No. MN119



ALUMINUM TRUCKS

ALUMINUM PLATFORM TRUCKS

- 40% lighter on average, than steel or wood-and-steel platform trucks
- Corrosion resistant for extra long life
- Box frame made of high strength all-welded aluminum channel
- Corner sockets at both ends allow handles to be used on either end of the truck
- Rubber corner bumpers prevent damage to walls and furniture
- Wide variety of casters to suit any application



8" PNEUMATIC CASTERS

| Platform Dimensions" | Capacity lbs. | Smooth Deck Model No. | Wt. lbs. | Tread Plate Deck Model No. | Wt. lbs. |
|----------------------|---------------|-----------------------|----------|----------------------------|----------|
| 24 x 36 | 1400 | ML901 | 51 | ML904 | 52 |
| 24 x 48 | 1400 | ML902 | 55 | ML905 | 57 |
| 30 x 60 | 1400 | ML903 | 66 | ML906 | 68 |

10" PNEUMATIC CASTERS

| Platform Dimensions" | Capacity lbs. | Smooth Deck Model No. | Wt. lbs. | Tread Plate Deck Model No. | Wt. lbs. |
|----------------------|---------------|-----------------------|----------|----------------------------|----------|
| 24 x 36 | 1850 | ML907 | 56 | ML910 | 57 |
| 24 x 48 | 1850 | ML908 | 60 | ML911 | 62 |
| 30 x 60 | 1850 | ML909 | 71 | ML912 | 73 |

8" FLAT-FREE CASTERS

| Platform Dimensions" | Capacity lbs. | Smooth Deck Model No. | Wt. lbs. | Tread Plate Deck Model No. | Wt. lbs. |
|----------------------|---------------|-----------------------|----------|----------------------------|----------|
| 24 x 36 | 1100 | ML913 | 54 | ML916 | 55 |
| 24 x 48 | 1100 | ML914 | 58 | ML917 | 60 |
| 30 x 60 | 1100 | ML915 | 69 | ML918 | 71 |

10" FLAT-FREE CASTERS

| Platform Dimensions" | Capacity lbs. | Smooth Deck Model No. | Wt. lbs. | Tread Plate Deck Model No. | Wt. lbs. |
|----------------------|---------------|-----------------------|----------|----------------------------|----------|
| 24 x 36 | 1200 | ML919 | 58 | ML922 | 59 |
| 24 x 48 | 1200 | ML920 | 62 | ML923 | 64 |
| 30 x 60 | 1200 | ML921 | 73 | ML924 | 75 |

8" MOLD-ON RUBBER CASTERS

| Platform Dimensions" | Capacity lbs. | Smooth Deck Model No. | Wt. lbs. | Tread Plate Deck Model No. | Wt. lbs. |
|----------------------|---------------|-----------------------|----------|----------------------------|----------|
| 24 x 36 | 2000 | ML925 | 64 | ML928 | 65 |
| 24 x 48 | 2000 | ML926 | 68 | ML929 | 70 |
| 30 x 60 | 2000 | ML927 | 79 | ML930 | 71 |

6" POLYURETHANE CASTERS

| Platform Dimensions" | Capacity lbs. | Smooth Deck Model No. | Wt. lbs. | Tread Plate Deck Model No. | Wt. lbs. |
|----------------------|---------------|-----------------------|----------|----------------------------|----------|
| 24 x 36 | 3400 | ML931 | 48 | ML934 | 49 |
| 24 x 48 | 3400 | ML932 | 52 | ML935 | 54 |
| 30 x 60 | 3400 | ML933 | 63 | ML936 | 65 |

8" POLYURETHANE CASTERS

| Platform Dimensions" | Capacity lbs. | Smooth Deck Model No. | Wt. lbs. | Tread Plate Deck Model No. | Wt. lbs. |
|----------------------|---------------|-----------------------|----------|----------------------------|----------|
| 24 x 36 | 4000 | ML937 | 53 | ML940 | 54 |
| 24 x 48 | 4000 | ML938 | 57 | ML941 | 59 |
| 30 x 60 | 4000 | ML939 | 68 | ML942 | 70 |



PLATFORM TRUCKS

STEEL DECK PLATFORM TRUCKS

Choose from a large selection of deck sizes and casters to suit any institutional and/or industrial application.

- Made of strong 14-gauge steel deck with a 2" folded bottom lip for extra strength
- Removable 1 1/4" tubular chrome handle can be inserted at either end of platform
- Two rigid and two swivel casters (assembly required, hardware is included)



CASTER WHEEL TYPES

Hi-Temp Nylon: Solid black nylon caster will not crush under heavy loads. Good for use on all types of surfaces from wood to concrete. Will tolerate temperatures from a low -28°C to a high of 230°C. Not affected by most corrosive chemicals.

Full Pneumatic: Air filled black rubber tire offers excellent shock absorbing properties. Smooth, quiet rolling over rough, uneven surfaces and outdoor terrain. Not recommended on floors with metal shavings or corrosive chemicals.

Mold-On Rubber: Molded rubber wheel bonded to a spoked cast iron core. The iron core gives it strength while the molded rubber provides easy, smooth and quiet rolling over rough terrain.

Non-Marking Rubber: Used for uneven surfaces and carpet areas. Its quiet rolling feature makes it ideal for both institutional and industrial applications. Will resist wet conditions and corrosive chemicals.

Polyolefin: Plastic wheel with high impact strength and non-chipping properties. Oil, grease and chemical resistant.



HEAVY-DUTY PLATFORM TRUCKS

WOOD DECK PLATFORM

- Sturdy 2" x 2" angle iron frame, with hardwood decking
- Ideal for carrying objects that scuff by metal to metal contact
- Steel frame absorbs shocks and handles uneven/heavy loads

ALL-STEEL PLATFORM

- Heavy 11-gauge, reinforced channel formed deck arc welded for maximum strength and long lasting rigidity
- Ideal for loads up to 2500 lbs.

CASTER PLACEMENT

- Available in standard-corner or diamond-tilt pattern
- Diamond tilt pattern allows the truck to tilt-balance slightly on the center side casters, allowing the truck to turn on its own length



Wood Deck



All Steel



Standard Corner Placement



Diamond Tilt Placement

CASTER SELECTION:

To select the correct caster that is required for a specific application determine:

- 1) Platform size needed
- 2) Maximum load capacity it will carry
- 3) Type of floor surface it will roll on i.e., concrete, wood, tile etc...
- 4) Floor condition i.e., smooth, uneven, wet, chemicals, metal shavings, temperature etc.

24" W X 36" L PLATFORM TRUCKS

| Model No. | Wheel Dia." | Wheel Type | Load Capacity/lbs. | Wt. lbs. |
|-----------|-------------|--------------------|--------------------|----------|
| MB232 | 6 | Hi-Temp Nylon | 1300 | 77 |
| MB233 | 8 | Hi-Temp Nylon | 1400 | 87 |
| MB234 | 8 | Pneumatic | 1000 | 79 |
| MB235 | 6 | Mold-On Rubber | 900 | 88 |
| MB236 | 8 | Mold-On Rubber | 1400 | 96 |
| MB237 | 5 | Non-Marking Rubber | 1200 | 63 |
| MB238 | 5 | Polyolefin | 900 | 61 |

24" W X 48" L PLATFORM TRUCKS

| Model No. | Wheel Dia." | Wheel Type | Load Capacity/lbs. | Wt. lbs. |
|-----------|-------------|--------------------|--------------------|----------|
| MB240 | 6 | Hi-Temp Nylon | 1300 | 90 |
| MB241 | 8 | Hi-Temp Nylon | 1400 | 100 |
| MB242 | 8 | Pneumatic | 1000 | 92 |
| MB243 | 6 | Mold-On Rubber | 900 | 101 |
| MB244 | 8 | Mold-On Rubber | 1400 | 109 |
| MB245 | 5 | Non-Marking Rubber | 1200 | 76 |
| MB246 | 5 | Polyolefin | 900 | 74 |

30" W X 48" L PLATFORM TRUCKS

| Model No. | Wheel Dia." | Wheel Type | Load Capacity/lbs. | Wt. lbs. |
|-----------|-------------|--------------------|--------------------|----------|
| MD421 | 6 | Hi-Temp Nylon | 1300 | 96 |
| MD422 | 8 | Hi-Temp Nylon | 1400 | 106 |
| MD423 | 8 | Pneumatic | 1000 | 98 |
| MD424 | 6 | Mold-On Rubber | 900 | 107 |
| MD425 | 8 | Mold-On Rubber | 1400 | 115 |
| MD426 | 5 | Non-Marking Rubber | 1200 | 82 |
| MD427 | 5 | Polyolefin | 900 | 80 |

30" W X 60" L PLATFORM TRUCKS

| Model No. | Wheel Dia." | Wheel Type | Load Capacity/lbs. | Wt. lbs. |
|-----------|-------------|--------------------|--------------------|----------|
| MB248 | 6 | Hi-Temp Nylon | 1300 | 110 |
| MB249 | 8 | Hi-Temp Nylon | 1400 | 120 |
| MB250 | 8 | Pneumatic | 1000 | 112 |
| MB251 | 6 | Mold-On Rubber | 900 | 121 |
| MB252 | 8 | Mold-On Rubber | 1400 | 129 |
| MB253 | 5 | Non-Marking Rubber | 1200 | 96 |
| MB254 | 5 | Polyolefin | 900 | 94 |

| 10" Pneumatic Wheels 1200 lbs. Cap. Model No. | 8" Rubber Wheels 2000 lbs. Cap. Model No. | 8" Hi-Temp Nylon Wheels 2500 lbs. Cap. Model No. | Platform Dimensions* W" x L" | Wt. lbs. |
|---|---|--|------------------------------------|-------------|
|---|---|--|------------------------------------|-------------|

WOOD DECK

| | | | | |
|-------|-------|-------|-----------|-----|
| MB256 | MB296 | MB130 | 24 x 48-C | 115 |
| MB258 | MB298 | MB133 | 24 x 48-T | 120 |
| MB264 | MB304 | MB138 | 30 x 48-C | 135 |
| MB266 | MB306 | MB141 | 30 x 48-T | 140 |
| MB267 | MB308 | MB142 | 30 x 60-C | 145 |
| MB270 | MD332 | MB145 | 30 x 60-T | 150 |
| MB279 | MB320 | MB155 | 36 x 72-C | 180 |
| MB282 | MB322 | MB157 | 36 x 72-T | 190 |
| MB284 | MB324 | MB166 | 48 x 96-C | 280 |
| MB286 | MB326 | MB169 | 48 x 96-T | 300 |

STEEL DECK

| | | | | |
|-------|-------|-------|-----------|-----|
| MB255 | MB295 | MB131 | 24 x 48-C | 110 |
| MB257 | MB297 | MB132 | 24 x 48-T | 115 |
| MB263 | MB303 | MB139 | 30 x 48-C | 130 |
| MB265 | MD331 | MB140 | 30 x 48-T | 135 |
| MB268 | MB307 | MB143 | 30 x 60-C | 140 |
| MB269 | MB309 | MB144 | 30 x 60-T | 145 |
| MB280 | MB319 | MB154 | 36 x 72-C | 175 |
| MB281 | MB321 | MB156 | 36 x 72-T | 185 |
| MB283 | MB323 | MB167 | 48 x 96-C | 240 |
| MB285 | MB325 | MB168 | 48 x 96-T | 265 |

* Suffix C after platform size signifies corner caster placement. T is diamond tilt.



CUSTOMISE IT TO YOUR SPECIFICATIONS.
SEE PAGE B71 FOR DETAILS

PLATFORM TRUCKS

HEAVY-DUTY PLATFORM TRUCKS

- Solid 7/8" hardwood deck with 5" x 1 5/8" hardwood sidewall
- Easy to manoeuvre with 44" high handle
- 15" deck height
- Two 12" hi-temp nylon load wheels and two 6" swivel casters
- Capacity: 3000 lbs.



| Model No. | Platform Dimensions | | | Wt. lbs. |
|-----------|---------------------|---|----|----------|
| | W" | x | L" | |
| MB122 | 24 | x | 48 | 150 |
| MB123 | 30 | x | 48 | 170 |
| MB124 | 30 | x | 60 | 195 |
| MB125 | 36 | x | 60 | 210 |
| MB126 | 36 | x | 72 | 230 |

PLASTIC PLATFORM TRUCKS

- HDPE-molded structural plastic for strength and long-term durability
- Lightweight, easy to clean, chemical resistant and resists damage from long-term exposure to weather conditions
- Non-skid deck surface
- Removable steel handle
- Other caster options and capacities available upon request
- Caster assembly required



| Model No. | Caster Type | Platform Size W" x L" | Deck Height" | Handle Height" | Capacity lbs. | Wt. lbs. |
|-----------|-------------------|-----------------------|--------------|----------------|---------------|----------|
| MN428 | 8" Mold-On Rubber | 24 x 48 | 11 | 39 | 2000 | 90 |
| MN429 | 8" Mold-On Rubber | 30 x 60 | 11 | 39 | 2000 | 117 |
| MN430 | 8" Polyurethane | 24 x 48 | 11 | 39 | 2500 | 79 |
| MN431 | 8" Polyurethane | 30 x 60 | 11 | 39 | 2500 | 106 |
| MN432 | 10" Pneumatic | 24 x 48 | 13 | 41 | 1200 | 84 |
| MN433 | 10" Pneumatic | 30 x 60 | 13 | 41 | 1200 | 111 |
| MN434 | 10" Flat-Free | 24 x 48 | 13 | 41 | 1000 | 85 |
| MN435 | 10" Flat-Free | 30 x 60 | 13 | 41 | 1000 | 117 |
| MN436 | 8" Pneumatic | 24 x 48 | 11 | 39 | 1000 | 79 |
| MN437 | 8" Pneumatic | 30 x 60 | 11 | 39 | 1000 | 106 |
| MN438 | 8" Flat-Free | 24 x 48 | 11 | 39 | 900 | 80 |
| MN439 | 8" Flat-Free | 30 x 60 | 11 | 39 | 900 | 107 |

HEAVY-DUTY PLATFORM TRUCKS

- Ideal for moving large and heavy loads
- Ergonomic handle design improves control and worker safety
- Powder-coated steel handle with retainer clips prevents unintended removal
- Steel reinforced deck for enhanced durability
- Molded-in-tie-down slots for load security
- Textured deck for enhanced durability
- Perimeter deck channel retains small items
- Two rigid and two swivel casters
- Assembly required



| Model No. | Overall Dimensions | | | | Caster Type | Capacity lbs. | Wt. lbs. | |
|-----------|--------------------|---|--------|---|-------------|---------------|----------|-----|
| | W" | x | L" | x | H" | | | |
| ML565 | 24 | x | 40 1/4 | x | 39 3/4 | 6" Rubber | 1000 | 58 |
| ML566 | 24 | x | 40 1/4 | x | 39 3/4 | 6" Polyolefin | 2000 | 63 |
| ML567 | 24 | x | 52 1/4 | x | 41 3/4 | 8" Rubber | 2000 | 76 |
| ML568 | 24 | x | 52 1/4 | x | 41 3/4 | 8" Pneumatic | 1200 | 76 |
| ML569 | 24 | x | 52 1/4 | x | 41 3/4 | 8" Polyolefin | 2500 | 80 |
| ML570 | 30 | x | 64 1/4 | x | 41 5/8 | 8" Rubber | 2000 | 87 |
| ML571 | 30 | x | 64 1/4 | x | 41 5/8 | 8" Pneumatic | 1200 | 87 |
| ML572 | 30 | x | 64 1/4 | x | 41 5/8 | 8" Polyolefin | 2500 | 100 |
| ML573 | 40 | x | 70 | x | 37 | 6" Rubber | 1000 | 127 |
| ML574 | 40 | x | 70 | x | 39 1/8 | 8" Pneumatic | 1000 | 127 |
| ML575 | 40 | x | 70 | x | 39 1/8 | 8" Polyolefin | 2000 | 127 |

WAGON TRUCKS

- Fifth wheel steering makes these trucks easy to manoeuvre under full loads
- 14 1/4" deck height
- 10" pneumatic wheels
- Capacity: 1000 lbs.
- Durable Kleiton blue enamel finish



| Wood Deck | | Steel Deck | | Platform Dim. | |
|-----------|----------|------------|----------|---------------|------|
| Model No. | Wt. lbs. | Model No. | Wt. lbs. | W" | x L" |
| MD186 | 120 | MD187 | 130 | 24 | x 48 |
| MD188 | 150 | MD189 | 170 | 30 | x 60 |
| MD192 | 190 | MD193 | 210 | 36 | x 72 |

ERGONOMIC PLATFORM TRUCKS

- Ergonomic handle is placed at a comfortable working height to alleviate back strains
- Picking list holder eliminates the need to handle loose papers
- Deck is constructed from 14-gauge all welded steel with a turned down lip and reinforced channels
- Two rigid and two swivel 8" mold-on rubber casters
- 48" L x 24" W
- Capacity: 1200 lbs.
- Kleiton powder coat finish



Model No. ML892

5TH WHEEL WAGON TRUCKS

- Ideal for moving heavy loads in manufacturing plants, warehouses, maintenance shops and outdoor environments
- Fifth wheel steering ensures tight turning radius and easy manoeuvrability
- Vinyl grip, powder coated "T" handle stays upright when not in use
- "T" handle is removable for towing capabilities (tow package sold separately)
- Steel reinforced deck for enhanced durability
- Molded-in tie-down slots for load security
- Textured deck channel and perimeter deck channel retains small items

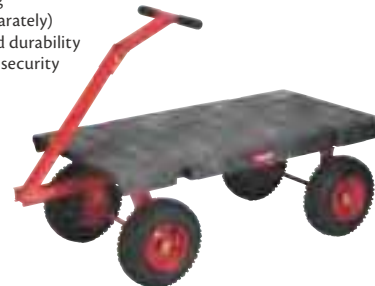

| Model No. | Overall Dimensions | | | | Caster Type | Capacity lbs. | Wt. lbs. | |
|-----------|--------------------|---|--------|---|-------------|---------------|----------|-----|
| | W" | x | L" | x | H" | | | |
| ML585 | 24 | x | 42 7/8 | x | 16 3/4 | 10" Pneumatic | 1200 | 60 |
| ML586 | 24 | x | 42 7/8 | x | 16 3/4 | 10" Rubber | 2000 | 60 |
| ML587 | 24 | x | 54 7/8 | x | 17 1/2 | 12" Pneumatic | 2000 | 71 |
| ML588 | 24 | x | 54 7/8 | x | 17 1/2 | 12" Rubber | 2000 | 71 |
| ML589 | 30 | x | 66 7/8 | x | 17 1/2 | 12" Pneumatic | 2000 | 88 |
| ML590 | 30 | x | 66 7/8 | x | 17 1/2 | 12" Rubber | 2000 | 88 |
| ML591 | 40 | x | 70 | x | 48 5/8 | 12" Pneumatic | 2000 | 125 |
| ML592 | 40 | x | 70 | x | 50 3/4 | 16" Pneumatic | 2000 | 130 |
| ML593 | Tow package | | | | - | - | 2.8 | |

INSTITUTIONAL PLATFORM TRUCKS

- Ideal truck for institutional applications - hospitals, restaurants, shopping centres, offices, industry and anywhere else a quiet ride and professional appearance is required
- 14-gauge steel deck with 2" lip underneath
- Non-skid rubber surface means product will not shift during use
- Rubber corner bumpers protect walls and furniture
- 1 1/4" tubular chrome handle with end panel contains small packages
- 5" non-marking rubber casters for a smooth, quiet ride; two rigid and two swivel
- Capacity: 1200 lbs
- Shipped knocked down



| Model No. | Dimensions | | | Wt lbs. |
|-----------|------------|---|----|---------|
| | W" | x | L" | |
| MB190 | 24 | x | 36 | 64 |
| MB208 | 24 | x | 48 | 70 |
| MB207 | 30 | x | 48 | 88 |
| MB209 | 30 | x | 60 | 100 |

FOLDING HANDLE PLATFORM TRUCKS

- Heavy gauge steel construction; non-skid vinyl coated deck
- Move supplies, forms and light equipment around the shop or office
- Quick-release handle folds flat for easy storage
- Vinyl wrap around bumper protects walls and furniture
- 5" rubber casters



| Model No. | Platform Dim. | | | Handle Height" | Cap. lbs. | Wt. lbs. |
|-----------|---------------|---|----|----------------|-----------|----------|
| | W" | x | L" | | | |
| MK988 | 19 | x | 29 | 33 1/2 | 400 | 28 |
| MK989 | 23 | x | 35 | 34 1/2 | 660 | 42 |

FOLDABLE PLATFORM TRUCKS

- Ideal when solid, portable platform truck is required
- Interlocking aluminum frame has dual length platform: 16" W x 20" L or 16" W x 28" L; handle height is 32"
- Standard with vinyl corner bumpers
- Folds down to a compact 16" W x 20" L x 9 1/2" H
- Rolls easily on 5" rubber casters
- Capacity: 300 lbs.
- Weight: 18 lbs.

Model No. MK990



CUSTOMISE IT TO YOUR SPECIFICATIONS.
SEE PAGE B71 FOR DETAILS

SEMI-LIVE SKIDS

- Ideal for temporary storage of materials
- Heavy 11-gauge steel deck with reinforced channels or 3/16" x 2" x 2" angle frame with hardwood deck
- 52" jack handle (sold separately) quickly engages skid and turns it into a portable truck that manoeuvres easily in confined areas
- Skids and handle come with 8" mold-on rubber wheels
- Capacity: 2000 lbs.
- Durable Kleaton blue enamel finish



| Steel Deck Model No. | Wt. lbs. | Wood Deck Model No. | Wt. lbs. | Deck Height | Platform Dimensions W" x L" |
|----------------------------|----------|---------------------|----------|-------------|-----------------------------|
| MB327 | 110 | MB328 | 115 | 12 | 24 x 48 |
| MB329 | 130 | MB330 | 135 | 12 | 30 x 48 |
| MB331 | 140 | MB332 | 145 | 12 | 30 x 60 |
| MB337 | 175 | MB338 | 180 | 12 | 36 x 72 |
| MB348 51" Long Jack Handle | | | 30 | | |

DEAD SKIDS

- Tough and durable platforms for temporary storage and handling of material
- Heavy 11-gauge steel deck with reinforced channels
- 3/16" x 2" x 2" angle frame with hardwood deck
- Available with steel or hardwood decks
- Four sturdy steel legs keep loads off the floor
- Can be stacked when not in use
- Capacity: 2500 lbs.
- Durable Kleaton blue enamel finish



| Model No. | Deck Dim. W" x L" | Platform Type | Deck Height" | Wt. lbs. |
|-----------|-------------------|---------------|--------------|----------|
| ML071 | 24 x 48 | Steel | 6 | 110 |
| ML072 | 24 x 48 | Wood | 6 | 115 |
| ML073 | 30 x 48 | Steel | 6 | 130 |
| ML074 | 30 x 48 | Wood | 6 | 135 |
| ML075 | 30 x 60 | Steel | 6 | 140 |
| ML076 | 30 x 60 | Wood | 6 | 145 |
| ML077 | 36 x 72 | Steel | 6 | 175 |
| ML078 | 36 x 72 | Wood | 6 | 180 |

TRIPLE™ TROLLEYS

- Three position handle lets users push, pull or fold flat for space efficient storage
- Non-skid surface helps prevent load shifting
- Durable, structural foam deck won't rust, dent or bend
- Mark resistant casters give stability over rough surfaces



| Model No. | Description | Dimensions W" x L" x H" | Cap. lbs. | Wt. lbs. |
|-----------|------------------|--------------------------|-----------|----------|
| MH708 | Standard Trolley | 20 1/2 x 32 1/2 x 37 3/4 | 500 | 25 |

LIFT TABLES

HYDRAULIC SCISSOR LIFT TABLES

Kleton tables are available in various capacities and travels to satisfy a wide variety of applications. All models have an integrated hydraulic pump/cylinder assembly. The Kleton scissor lift tables add the value of mobility to the hydraulic lift table concept. Exceptional functionality and manoeuvrability is apparent, whether loaded or empty. In addition, rugged construction and premium-quality hydraulics complement their ease of use with low maintenance.

APPLICATIONS

Kleton tables are used in a wide variety of applications, from stocking shelves in retail stores to lifting and moving materials in warehouses, machine shops and manufacturing operations.

OPERATION

The Kleton design allows workers to easily move and position loads to a convenient working height. By minimising undesirable lifting, reaching and stretching, Kleton tables increase productivity and decrease workplace injuries.



STANDARD FEATURES

- Heavy-duty construction with captured scissor rollers for maximum stability
- Superior hydraulic systems feature an integrated pump-cylinder for maximum reliability
- High quality casters and wheels for exceptional roll ability (two fixed, two swivel)
- Ergonomic push handle with convenient lowering control
- Lowering control automatically stops when released for added safety
- Convenient maintenance pins secure the scissor legs for inspection and maintenance on larger models
- Quality powder coated finish provides exceptional durability and corrosion resistance
- Kleton blue



| Model No. | Load Cap. lbs. | Platform Height | | Platform Dimensions | | Handle Height" | Pedal Strokes To Max | Wt. lbs. |
|-----------|----------------|-----------------|---------|---------------------|---------|----------------|----------------------|----------|
| | | Lowered" | Raised" | Width" | Length" | | | |
| MJ518 | 330 | 8 5/8 | 29 | 17 3/4 | 27 1/2 | 37 3/8 | 28 | 99 |
| MJ519 | 660 | 11 1/4 | 34 5/8 | 19 3/4 | 32 | 39 | 27 | 170 |
| MJ520* | 770 | 14 | 51 1/4 | 19 3/4 | 35 3/4 | 38 3/8 | 53 | 230 |
| MJ521 | 1100 | 11 1/4 | 34 5/8 | 19 3/4 | 32 | 39 | 27 | 179 |
| MJ522 | 1100 | 11 1/4 | 36 | 31 7/8 | 63 | 39 | 55 | 340 |
| MJ523 | 1650 | 16 1/2 | 35 3/8 | 20 1/8 | 39 3/8 | 39 3/8 | 45 | 275 |
| MJ524 | 2200 | 15 | 39 | 20 1/8 | 40 | 38 5/8 | 82 | 269 |
| MJ525 | 2200 | 11 3/4 | 53 1/2 | 29 1/2 | 80 1/8 | 39 3/8 | 200 | 770 |
| MJ526* | 1760 | 17 1/2 | 59 1/8 | 24 | 48 | 40 | 97 | 430 |

*Double scissors

HYDRAULIC WORK TABLES

- All-welded construction
- Foot operated lifts are ideal for wide variety of shop functions (lifting dies, transporting heavy parts and positioning materials)
- Hand operated lever lowers the table level and controls the rate of descent
- Telescoping posts for stability and support
- Tops and bases are 3/16" thick steel
- Floor lock ensures table remains in place when loaded



| Model No. | Table Height | | Table Dimensions | | Cap. lbs. | Wt. lbs. |
|-----------|--------------|---------|------------------|--------|-----------|----------|
| | Lowered" | Raised" | Length" x | Width" | | |
| MA433 | 28 1/2 | 46 | 16 x | 16 | 200 | 54 |
| MA434 | 30 1/2 | 47 1/2 | 18 x | 18 | 500 | 122 |
| MA435 | 30 1/2 | 47 1/2 | 18 x | 36 | 1000 | 268 |
| MA442 | 30 1/2 | 47 1/2 | 36 x | 24 | 2000 | 225 |
| MA443 | 30 1/2 | 47 1/2 | 48 x | 32 | 2000 | 350 |

Other dimensions and capacities available

AIR PALLET PAL LEVEL LOADERS

- Designed for use where pallet loads vary and are changed frequently
- 43 5/8" diameter rolled angle ring riding on low friction bearings and guided by center shaft
- Permanent spring combines with air bag to provide linear response
- Equipped with fork pockets for easy relocation
- Lowered height of 9 1/2", raised height of 30 1/2"
- Base frame dimensions: 48" L x 36" W, including fork truck pockets
- Capacity: 400 to 4500 lbs.
- Weight: 460 lbs.

Model No. LT471



SOUTHWORTH



LIFT TABLES & SKID LIFTS

DANDY LIFT™

- Dandy Lift™ offers the ideal solution to reliable, economic lifting over years of service
- Pivot points have hardened pins in lifetime lubricated bearings
- Simple grouped controls make tables easy to operate
- Hard chrome-plated pistons and rods resist rust and corrosion for dependability and long life
- Honed heavy-walled cylinders improve both seal performance and durability

Built to last, all Dandy Lift™ tables are designed using heavy steel structural components.

LOW PROFILE DANDY LIFT™

- Ideal for use in factories, warehouses and repair shops
- Fully lowered height of only 3 1/5"
- Platform fits easily under most skids and wire baskets
- Comes with two rigid and two swivel rubber casters
- Floor lock brake is standard



SOUTHWORTH

| Model No. | Platform | | Platform Dim. | | | Overall Dim. | | | Foot pedal Strokes to Max. | Cap. lbs. | Wt. lbs. |
|-----------|----------|---------|---------------|---|---------|--------------|---|---------|----------------------------|-----------|----------|
| | Lowered" | Raised" | L" | x | W" | L" | x | W" | | | |
| MA431 | 8 3/10 | 29 | 28 | x | 17 7/10 | 37 7/10 | x | 17 7/10 | 14 | 330 | 82 |
| MA432 | 9 1/2 | 31 1/2 | 31 1/2 | x | 19 7/10 | 38 1/5 | x | 19 7/10 | 20 | 550 | 115 |
| MA421 | 13 3/5 | 49 4/5 | 35 4/5 | x | 23 3/5 | 42 1/10 | x | 23 3/5 | 45 | 770 | 229 |
| MA422 | 11 4/5 | 36 3/5 | 35 4/5 | x | 23 3/5 | 42 1/10 | x | 23 3/5 | 45 | 1100 | 194 |
| MA423 | 13 | 40 1/5 | 39 2/5 | x | 23 3/5 | 45 9/10 | x | 23 3/5 | 56 | 1760 | 275 |
| MA464* | 3 1/5 | 29 1/2 | 37 1/10 | x | 19 7/10 | 55 2/5 | x | 19 7/10 | 15 | 1100 | 174 |

* Low profile

SCISSOR LIFT PALLET TRUCK

- Frame material : Steel
- Lifting capacity: 2500 lbs.
- Fork width: 7"
- Raised height: 31.5"
- Lowered height: 3.5"
- Steel load backrest
- Leak-proof pump w/overload protect
- Automatic brake system
- 3-position finger tip control handle
- Dual cylinder w/chain pull design
- 3" nylon load rollers
- 4" x 2" phenolic swivel casters

BATTERY POWERED LIFT

- Fully raised in 6 seconds
- Approx. 50 max. load lifts on one battery charge
- Heavy duty 12 V, 125 Ah industrial strength battery
- 10 A charger with transformer, circuit breaker and overload protection
- Can be plugged into any standard 110 V outlet



| Model No. | Mfg. No. | Fork Dimensions | | |
|-----------------------------|--------------|-----------------|---|------|
| | | L" | x | W" |
| MANUAL LIFT | | | | |
| LU009 | MPS25-117220 | 48 | x | 20.5 |
| LU010 | MPS25-117227 | 48 | x | 27 |
| BATTERY POWERED LIFT | | | | |
| LU013 | BPS25-118220 | 42 1/2 | x | 27 |
| LU014 | BPS25-118227 | 42 1/2 | x | 27 |

SKID LIFTS

- Allows entry into different skids and baskets
- Lightweight design is easy to manoeuvre with pallet truck style steering configuration
- Strong and reliable cylinder
- Quick-lift mechanism on manual lifts allows loads under 400 lbs. to be raised with 24 strokes, heavier loads require 72 strokes
- Self-contained battery powered power pack (electric models) eliminates power source or power cord problems
- Built-in automatic battery charger and charge indicator (electric models)

- Raised bulkhead design provides greater backrest surface, ergonomic location for automatic battery charger and clear view of load
- 24" load centre
- Lowered height: 3 1/4", raised height: 31 1/2"
- 8" polyurethane load wheels and 3" polyurethane load roller
- Capacity: 3000 lbs.



MANUAL LIFTS

| Model No. | Fork Dimensions | | Wt. lbs. |
|-----------|-----------------|-----|----------|
| | L" | W" | |
| MH748 | 48 x 20 1/2 | 330 | |
| MH749 | 48 x 27 | 340 | |

ELECTRIC LIFTS

| Model No. | Fork Dimensions | | Wt. lbs. |
|-----------|-----------------|-----|----------|
| | L" | W" | |
| MH796 | 48 x 20 1/2 | 430 | |
| MH797 | 48 x 27 | 440 | |



WAREHOUSE TRUCKS & CARTS

FRAME SHEET/PANEL TRUCKS

- All-welded truck is ideal for handling long, flat, awkward loads
- Available with open or closed base
- Four bolted-on 5" non-marking rubber swivel casters
- Capacity: 1200 lbs.
- Durable Kleton blue enamel finish



| Model No. | Base Type | Overall Dimensions | | | | | Wt. lbs. |
|-----------|-----------|--------------------|---|----|---|----|----------|
| | | W" | x | L" | x | H" | |
| MD216 | Open | 24 | x | 36 | x | 55 | 50 |
| ML063 | Closed | 24 | x | 36 | x | 5 | 60 |
| MD217 | Open | 30 | x | 42 | x | 55 | 60 |
| ML064 | Closed | 30 | x | 42 | x | 55 | 75 |
| MD218 | Open | 36 | x | 72 | x | 55 | 85 |
| ML065 | Closed | 36 | x | 72 | x | 55 | 110 |

| REPLACEMENT CASTERS | |
|---------------------|-------------------------------------|
| ML337 | 5" Swivel Non-Marking Rubber Caster |

DRYWALL CARTS

- All-welded multi-purpose cart is ideal for transporting drywall, wood or metal sheets
- 1 1/4" tubular rail handle and thick 11-gauge steel platform
- Two rigid and two swivel 8" bolted-on casters
- Deck dimensions: 15" W x 44" L x 14" H
- Overall dimensions: 24" W x 44" L x 44" H
- Durable Kleton blue enamel finish



| Model No. | Caster Type | Deck Angle° | Cap. lbs. | Wt. lbs. |
|-----------|-------------------|-------------|-----------|----------|
| ML139 | 8" Mold-On Rubber | 80 | 2000 | 115 |
| MD214 | 8" Polyurethane | 80 | 3500 | 110 |

LUMBER CARTS

- All-welded cart is ideal for transporting long and bulky items
- Welded 14-gauge 12" x 38" steel shelf
- Grey rubber bumpers protect walls and equipment
- Two rigid and two swivel bolted-on casters
- Capacity: 1200 lbs.
- Durable Kleton blue enamel finish



| Model No. | Deck Dim. | | | Shelf Height" | Overall Dim. | | | Caster Type | Wt. lbs |
|-----------|-----------|---|---------|---------------|--------------|---|---------|-------------|---------|
| | W" | x | L" x H" | | W" | x | L" x H" | | |
| MB729 | 24 | x | 36 x 8 | 34 | 26 | x | 39 x 42 | 5" Rubber | 80 |
| ML140 | 24 | x | 36 x 10 | 36 | 26 | x | 39 x 45 | 6" Rubber | 100 |

HIGH END PLATFORM TRUCKS

- Tilt design allows truck to turn within its own radius
- 11-gauge steel deck is only 10" off the ground for easy loading
- Removable end racks constructed of 1 1/4" round steel tube
- Two 8" x 2" bolted-on rigid caster and four 5" swivel casters
- Capacity: 1500 lbs.
- Durable Kleton blue enamel finish

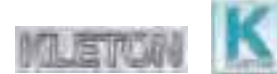

| Model No. | Overall Dimensions | | | | | Wt. lbs. |
|-----------|--------------------|---|----|---|----|----------|
| | W" | x | L" | x | H" | |
| MK970 | 18 | x | 48 | x | 72 | 115 |
| MK971 | 18 | x | 60 | x | 72 | 125 |

HEAVY-DUTY PANEL & LUMBER MOVER TRUCKS

- All-welded, ready to use
- Constructed from 1 1/4" round tubing and an 11-gauge deck
- Ideal for transporting large sheets and long parts
- Uprights extend 21" and 33" above deck
- Deck is 12" off the floor
- 8" clear space between tubes
- Two rigid and two swivel 8" casters
- Durable Kleton blue enamel finish



| Model No. | Overall Dimensions | | | | | Caster Type | Cap. lbs. | Wt. lbs. |
|-----------|--------------------|---|----|---|----|----------------|-----------|----------|
| | W" | x | L" | x | H" | | | |
| ML360 | 30 | x | 48 | x | 45 | Mold-On Rubber | 2000 | 160 |
| ML361 | 30 | x | 48 | x | 45 | Polyurethane | 2500 | 175 |
| ML362 | 30 | x | 60 | x | 45 | Mold-On Rubber | 2000 | 160 |
| ML363 | 30 | x | 60 | x | 45 | Polyurethane | 2500 | 175 |

SINGLE LEVEL RAILS HEAVY-DUTY PANEL MOVER TRUCKS

- All-welded truck ideal for transporting large sheets and long parts
- Construction from 1 1/4" round tubing and reinforced 11-gauge deck
- Uprights extend 33" above deck
- Deck is 12" off the floor
- Overall height is 45"
- 8" clear space between tubes
- Two rigid and two swivel 8" casters
- Durable Kleton blue enamel finish



| Model No. | Overall Dimensions | | | | | Caster Type | Capacity lbs. | Wt. lbs. |
|-----------|--------------------|---|----|---|----|-------------------|---------------|----------|
| | W" | x | L" | x | H" | | | |
| ML549 | 30 | x | 48 | x | 45 | 8" Mold-On Rubber | 2000 | 139 |
| ML550 | 30 | x | 48 | x | 45 | 8" Polyurethane | 2500 | 139 |
| ML551 | 30 | x | 60 | x | 45 | 8" Mold-On Rubber | 2000 | 161 |
| ML552 | 30 | x | 60 | x | 45 | 8" Polyurethane | 2500 | 161 |

K CUSTOMISE IT TO YOUR SPECIFICATIONS.
SEE PAGE B71 FOR DETAILS

COMMERCIAL DUTY SHELF CARTS

HEAVY-DUTY LOW PROFILE SHOP CARTS

- All-welded cart with low shelf means less distance to lift heavy objects
- Two 14-gauge steel shelves with a 1 1/2" lip down
- 1 1/4" diameter tubular steel handle
- Two rigid and two swivel bolted-on casters
- Durable Kleton blue enamel finish



5" RUBBER CASTERS

- Non-marking casters are quiet rolling and ideal for both institutional and industrial applications
- Casters are resistant to wet and corrosive chemical conditions
- Capacity: 1200 lbs. evenly distributed

| Model No. | Shelf Dimensions W" x L" | Clearance Between Shelves" | Top Shelf Height" | O.A. Dim. W" x L" x H" | Wt. lbs. |
|-----------|--------------------------|----------------------------|-------------------|------------------------|----------|
| MB421 | 18 x 30 | 16 | 26 | 18 x 34 x 40 | 90 |
| MB425 | 24 x 36 | 16 | 26 | 24 x 40 x 40 | 110 |
| MB429 | 24 x 48 | 16 | 26 | 24 x 52 x 40 | 125 |
| ML097 | 24 x 60 | 16 | 26 | 24 x 64 x 40 | 155 |
| ML098 | 30 x 48 | 16 | 26 | 30 x 52 x 40 | 155 |
| MB434 | 30 x 60 | 16 | 26 | 30 x 64 x 40 | 165 |
| ML099 | 30 x 72 | 16 | 26 | 30 x 76 x 40 | 175 |

6" HI-TEMP NYLON OR POLYURETHANE CASTERS

- Solid black hi-temp nylon casters handle heavy loads easily
- Solid polyurethane casters are non-marking and are highly resistant to wear
- Best choice in uneven floor applications
- Capacity: 2400 lbs. evenly distributed

| 6" Nylon Model No. | 6" Polyurethane Model No. | Shelf Dim. W" x L" | Clearance Between Shelves" | Top Shelf Height" | O.A. Dim. W" x L" x H" | Wt. lbs |
|--------------------|---------------------------|--------------------|----------------------------|-------------------|------------------------|---------|
| MB422 | ML103 | 18 x 30 | 16 | 27 | 18 x 34 x 41 | 100 |
| MB426 | ML104 | 24 x 36 | 16 | 27 | 24 x 40 x 41 | 130 |
| MB430 | ML105 | 24 x 48 | 16 | 27 | 24 x 52 x 41 | 145 |
| ML100 | ML106 | 24 x 60 | 16 | 27 | 24 x 64 x 41 | 155 |
| ML101 | ML107 | 30 x 48 | 16 | 27 | 30 x 52 x 41 | 155 |
| MB435 | ML108 | 30 x 60 | 16 | 27 | 30 x 64 x 41 | 165 |
| ML102 | ML109 | 30 x 72 | 16 | 27 | 30 x 76 x 41 | 175 |

STOCK PICKING CARTS

- All-welded design for durability and long life
- Pick and transport stock without the need for a separate ladder
- Slip-resistant steps and positive locking engagement for safety
- Step rise: 9 1/2"
- Three 14-gauge steel shelves with 1 1/2" lip, configured up
- Clearance between shelves: 12"
- Two rigid and two swivel bolted-on 5" non-marking rubber casters
- Capacity: 1200 lbs. evenly distributed
- Durable Kleton blue enamel finish

MB507



| Model No. | Shelf Dim. W" x D" | Number of Steps | Step Dim. W" x D" | Overall Dimensions W" x D" x H" | Wt. lbs. |
|-----------|--------------------|-----------------|-------------------|---------------------------------|----------|
| MD441 | 24 x 36 | 3 | 22 x 4 | 24 x 52 x 61 | 135 |
| MB507 | 24 x 48 | 3 | 22 x 4 | 24 x 64 x 61 | 140 |
| MD442 | 24 x 36 | 5 | 22 x 4 | 24 x 52 x 78 | 145 |
| MB508 | 24 x 48 | 5 | 22 x 4 | 24 x 64 x 78 | 150 |

CUSTOMISE IT TO YOUR SPECIFICATIONS. SEE PAGE B71 FOR DETAILS

SHELF/PLATFORM TRUCKS

- 2-in-1 shelf truck features removable top shelf and post assembly - converts into a platform truck when removed
- Standard features include: two front corner non-marking bumpers, four 5" non-marking rubber casters (two rigid and two swivel), two crossbars on push handle, all-welded heavy gauge steel assembly
- Shelf dimensions: 24" W x 36" L
- Top shelf capacity: 500 lbs. evenly distributed
- Bottom shelf capacity: 800 lbs. evenly distributed
- Durable Kleton blue enamel finish



| Model No. | O.A. Dim. W" x L" x H" | Top Shelf H" | Wt. lbs. |
|-----------|------------------------|--------------|----------|
| MB391 | 26 x 38 x 40 | 32 | 105 |

DEEP-LIPPED SERVICE CARTS

- All-welded design, ready-to-use
- Deep shelf lips for retention
- Two 14-gauge steel shelves welded to 1 1/2" x 1 1/2" x 1/8" steel posts
- 1" diameter tubular ergonomic handle
- Two rigid and two swivel 5" non-marking rubber casters
- Overall dimensions: 24" W x 42" D x 47" H
- Capacity: 1200 lbs. evenly distributed
- Durable Kleton blue enamel finish



| Model No. | Shelf Dim. W" x D" | Shelf Lip Depth | Clearance Between Shelves | Wt. lbs. |
|-----------|--------------------|-----------------------|---------------------------|----------|
| MN393 | 24 x 36 | Top 6"/Bottom 1 1/2" | 22 1/2" | 85 |
| MN394 | 24 x 36 | Top 12"/Bottom 1 1/2" | 16" | 90 |
| MN395 | 24 x 36 | Top 6"/Bottom 6" | 18" | 90 |

MOBILE SERVICE CARTS

- All-welded design, ready-to-use
- Louvered panels for small parts bins and lockable drawer for supplies
- Two 14-gauge steel shelves welded to 1 1/2" x 1 1/2" x 1/8" steel posts
- 1" diameter tubular handle
- Two rigid and two swivel with brake bolted-on 5" non-marking rubber casters
- Overall dimensions: 24" W x 40" L x 57" H
- Capacity: 1200 lbs. evenly distributed
- Durable Kleton blue enamel finish



| Model No. | Shelf Dim. W" x D" | Description | Clearance Between Shelves | Wt. lbs. |
|-----------|--------------------|-----------------------------|---------------------------|----------|
| MN396 | 24 x 36 | Top Lip Down /Bottom Lip Up | 18" | 88 |

ELEVATED PLATFORM TRUCKS

- All-welded steel construction, ready-to-use
- 11-gauge steel deck with 2" square tube frames
- 1 1/4" round tube handle extends 14" above deck
- Removable handle
- Durable Kleton blue enamel finish



| Model No. | Platform Dimensions W" x L" | Deck Height | Wheel Type | Capacity lbs. | Wt. lbs. |
|-----------|-----------------------------|-------------|-------------------|---------------|----------|
| MN413 | 24 x 48 | 28" | 8" Hi-Temp Nylon | 2000 | 140 |
| MN414 | 30 x 60 | 28" | 8" Hi-Temp Nylon | 2000 | 172 |
| MN415 | 24 x 48 | 28" | 8" Mold-On Rubber | 1800 | 140 |
| MN416 | 30 x 60 | 28" | 8" Mold-On Rubber | 1800 | 172 |
| MN417 | 24 x 48 | 31" | 10" Pneumatic | 1000 | 140 |
| MN418 | 30 x 60 | 31" | 10" Pneumatic | 1000 | 172 |

COMMERCIAL DUTY SHELF CARTS

KNOCKED-DOWN SHELF CARTS

- 16-gauge steel shelves with 2 1/2" high lip
- 1 1/2" x 1 1/2" x 12-gauge formed steel posts
- 1 1/4" diameter tubular steel handle
- Top and middle shelves can be installed lip up or down
- Two rigid and two swivel bolted-on casters
- Easy-to-assemble shipped knocked-down design
- Capacity: 900 lbs. evenly distributed
- Durable Kleton blue powder coat finish



MB492



MB496



2-SHELF UTILITY CARTS

| Model No. | Shelf Dim. W" x D" | Shelf Clearance" | Post Height" | Overall Height" | Wt. lbs. |
|---------------------------------------|--------------------|------------------|--------------|-----------------|----------|
| 5" BLUE ELASTIC RUBBER CASTERS | | | | | |
| MB492 | 18 x 30 | 25 | 30 | 36 | 43 |
| MB493 | 24 x 36 | 25 | 30 | 36 | 54 |
| MB494 | 24 x 48 | 25 | 30 | 36 | 69 |
| 5" POLYOLEFIN CASTERS | | | | | |
| MB482 | 18 x 30 | 25 | 30 | 36 | 42 |
| MB483 | 24 x 36 | 25 | 30 | 36 | 53 |
| MB484 | 24 x 48 | 25 | 30 | 36 | 68 |
| 8" PNEUMATIC CASTERS | | | | | |
| MB488 | 24 x 36 | 25 | 30 | 40 | 60 |
| MB489 | 24 x 48 | 25 | 30 | 40 | 75 |

4-SHELF UTILITY CARTS

| Model No. | Shelf Dim. W" x D" | Shelf Clearance" | Post Height" | Overall Height" | Wt. lbs. |
|---------------------------------------|--------------------|------------------|--------------|-----------------|----------|
| 5" BLUE ELASTIC RUBBER CASTERS | | | | | |
| ML145 | 18 x 30 | 10 | 42 | 48 | 66 |
| ML146 | 24 x 36 | 10 | 42 | 48 | 85 |
| ML147 | 24 x 48 | 10 | 42 | 48 | 115 |
| ML148 | 18 x 30 | 15 | 55 | 61 | 68 |
| ML149 | 24 x 36 | 15 | 55 | 61 | 87 |
| ML150 | 24 x 48 | 15 | 55 | 61 | 117 |
| 5" POLYOLEFIN CASTERS | | | | | |
| MN148 | 18 x 30 | 10 | 42 | 48 | 65 |
| MN149 | 24 x 36 | 10 | 42 | 48 | 84 |
| MN150 | 24 x 48 | 10 | 42 | 48 | 114 |
| MN151 | 18 x 30 | 15 | 55 | 61 | 67 |
| MN152 | 24 x 36 | 15 | 55 | 61 | 86 |
| MN153 | 24 x 48 | 15 | 55 | 61 | 116 |
| 8" PNEUMATIC CASTERS | | | | | |
| MN154 | 24 x 36 | 10 | 42 | 52 | 90 |
| MN155 | 24 x 48 | 10 | 42 | 52 | 120 |
| MN156 | 24 x 36 | 15 | 55 | 65 | 92 |
| MN157 | 24 x 48 | 15 | 55 | 65 | 122 |

3-SHELF UTILITY CARTS

| Model No. | Shelf Dim. W" x D" | Shelf Clearance" | Post Height" | Overall Height" | Wt. lbs. |
|---------------------------------------|--------------------|------------------|--------------|-----------------|----------|
| 5" BLUE ELASTIC RUBBER CASTERS | | | | | |
| MB495 | 18 x 30 | 11 | 30 | 36 | 54 |
| MB496 | 24 x 36 | 11 | 30 | 36 | 70 |
| MB497 | 24 x 48 | 11 | 30 | 36 | 93 |
| ML142 | 18 x 30 | 17 | 42 | 48 | 56 |
| ML143 | 24 x 36 | 17 | 42 | 48 | 72 |
| ML144 | 24 x 48 | 17 | 42 | 48 | 95 |
| 5" POLYOLEFIN CASTERS | | | | | |
| MB485 | 18 x 30 | 11 | 30 | 36 | 53 |
| MB486 | 24 x 36 | 11 | 30 | 36 | 69 |
| MB487 | 24 x 48 | 11 | 30 | 36 | 92 |
| MN143 | 18 x 30 | 17 | 42 | 48 | 55 |
| MN144 | 24 x 36 | 17 | 42 | 48 | 71 |
| MN145 | 24 x 48 | 17 | 42 | 48 | 94 |
| 8" PNEUMATIC CASTERS | | | | | |
| MB490 | 24 x 36 | 11 | 30 | 40 | 77 |
| MB491 | 24 x 48 | 11 | 30 | 40 | 100 |
| MN146 | 24 x 36 | 17 | 42 | 52 | 79 |
| MN147 | 24 x 48 | 17 | 42 | 52 | 102 |

5-SHELF UTILITY CARTS

| Model No. | Shelf Dim. W" x D" | Shelf Clearance" | Post Height" | Overall Height" | Wt. lbs. |
|---------------------------------------|--------------------|------------------|--------------|-----------------|----------|
| 5" BLUE ELASTIC RUBBER CASTERS | | | | | |
| ML151 | 18 x 30 | 10 | 55 | 61 | 80 |
| ML152 | 24 x 36 | 10 | 55 | 61 | 100 |
| ML153 | 24 x 48 | 10 | 55 | 61 | 135 |
| 5" POLYOLEFIN CASTERS | | | | | |
| MN158 | 18 x 30 | 10 | 55 | 61 | 79 |
| MN159 | 24 x 36 | 10 | 55 | 61 | 99 |
| MN160 | 24 x 48 | 10 | 55 | 61 | 134 |
| 8" PNEUMATIC CASTERS | | | | | |
| MN161 | 24 x 36 | 10 | 55 | 65 | 105 |
| MN162 | 24 x 48 | 10 | 55 | 65 | 140 |

ERGONOMIC SHELF CARTS

- All-welded 16-gauge construction
- All-welded ergonomic handle placed at a comfortable working height
- Two rigid and two swivel 5" casters
- Capacity: 800 lbs. evenly distributed
- Durable Kleton blue enamel finish



ML561

| Model No. | Number of Shelves | Caster Type | Overall Dimensions W" x D" x H" |
|-----------|-------------------|-------------|---------------------------------|
| ML561 | 2 | Blue Rubber | 20 x 32 x 37 |
| MN056 | 2 | Blue Rubber | 26 x 38 x 37 |
| ML562 | 3 | Blue Rubber | 20 x 32 x 37 |
| MN055 | 3 | Blue Rubber | 26 x 38 x 37 |
| ML563 | 2 | Polyolefin | 20 x 32 x 37 |
| ML883 | 2 | Polyolefin | 26 x 38 x 37 |
| ML564 | 3 | Polyolefin | 20 x 32 x 37 |
| ML884 | 3 | Polyolefin | 26 x 38 x 37 |



CUSTOMISE IT TO YOUR SPECIFICATIONS.
SEE PAGE B71 FOR DETAILS

HEAVY-DUTY SHELF CARTS

HEAVY-DUTY SHELF CARTS

- All-welded design ready to use
- Cart constructed from 14-gauge steel shelves welded to 1 1/2" x 1 1/2" x 1/8" steel angle posts
- Versatile for all material transport
- 1" diameter tubular steel handle
- Shelves are available with a 1 1/2" lip configured up or down
- Two rigid and two swivel 5" non-marking casters
- Capacity: 1200 lbs. evenly distributed
- Durable Kleton blue enamel finish



MB461



MB476

OVERALL HEIGHT: 36"

| Lip Up Model No. | Lip Down Model No. | Shelf Dimensions W" x D" | No. Shelves | Clearance Between Shelves" | Handle Height" | Overall Dimensions W" x D" x H" | Wt. lbs. |
|------------------|--------------------|--------------------------|-------------|----------------------------|----------------|---------------------------------|----------|
| MB445 | MB444 | 18 x 30 | 2 | 27 | 36 | 18 x 33 x 36 | 60 |
| MB447 | MB446 | 24 x 36 | 2 | 27 | 36 | 24 x 39 x 36 | 65 |
| MB449 | MB448 | 24 x 48 | 2 | 27 | 36 | 24 x 51 x 36 | 100 |
| MB456 | MB455 | 18 x 30 | 3 | 12 | 36 | 18 x 33 x 36 | 75 |
| MB459 | MB458 | 24 x 36 | 3 | 12 | 36 | 24 x 39 x 36 | 85 |
| MB461 | MB460 | 24 x 48 | 3 | 12 | 36 | 24 x 51 x 36 | 110 |

OVERALL HEIGHT: 48"

| Lip Up Model No. | Lip Down Model No. | Shelf Dimensions W" x D" | No. Shelves | Clearance Between Shelves" | Handle Height" | Overall Dimensions W" x D" x H" | Wt. lbs. |
|------------------|--------------------|--------------------------|-------------|----------------------------|----------------|---------------------------------|----------|
| ML084 | ML083 | 18 x 30 | 3 | 18 | 42 | 18 x 33 x 48 | 80 |
| ML086 | ML085 | 24 x 36 | 3 | 18 | 42 | 24 x 39 x 48 | 90 |
| ML088 | ML087 | 24 x 48 | 3 | 18 | 42 | 24 x 51 x 48 | 115 |
| ML090 | ML089 | 18 x 30 | 4 | 12 | 42 | 18 x 33 x 48 | 110 |
| ML092 | ML091 | 24 x 36 | 4 | 12 | 42 | 24 x 39 x 48 | 135 |
| ML094 | ML093 | 24 x 48 | 4 | 12 | 42 | 24 x 51 x 48 | 160 |

OVERALL HEIGHT: 61"

| Lip Up Model No. | Lip Down Model No. | Shelf Dimensions W" x D" | No. Shelves | Clearance Between Shelves" | Handle Height" | Overall Dimensions W" x D" x H" | Wt. lbs. |
|------------------|--------------------|--------------------------|-------------|----------------------------|----------------|---------------------------------|----------|
| MB468 | MB467 | 18 x 30 | 4 | 16 | 42 | 18 x 33 x 61 | 115 |
| MB470 | MB469 | 24 x 36 | 4 | 16 | 42 | 24 x 39 x 61 | 140 |
| MB472 | MB471 | 24 x 48 | 4 | 16 | 42 | 24 x 51 x 61 | 165 |
| MB474 | MB473 | 18 x 30 | 5 | 11 | 42 | 18 x 33 x 61 | 125 |
| MB476 | MB475 | 24 x 36 | 5 | 11 | 42 | 24 x 39 x 61 | 155 |
| MB478 | MB477 | 24 x 48 | 5 | 11 | 42 | 24 x 51 x 61 | 184 |



ML092

HEAVY-DUTY SHELF CARTS WITH DRAWER

- All-welded design ready to use
- Carts constructed from 14-gauge steel shelves welded to 1 1/2" x 1 1/2" x 1/8" steel angle posts
- 1" diameter tubular steel handle
- Drawer dimensions: 15 1/4" W x 20" D x 6" H, 100-lb. capacity
- Available with two or three shelves with 1 1/2" lip configured up
- Two rigid and two swivel bolted-on 5" non-marking casters
- Capacity: 1200 lbs. evenly distributed
- Durable Kleton blue enamel finish



MH255

| Model No. | Shelf Dimensions W" x D" | Number of Shelves | Clearance Between Shelves" | Drawer to Shelf Clearance" | Handle Height" | Overall Dimensions W" x D" x H" | Wt. lbs. |
|-----------|--------------------------|-------------------|----------------------------|----------------------------|----------------|---------------------------------|----------|
| MH255 | 24 x 36 | 2 | 27 | 18 | 36 | 24 x 39 x 36 | 75 |
| MH256 | 24 x 36 | 3 | 12 | 3 | 36 | 24 x 39 x 36 | 95 |

ORDER PICKING CARTS

- All-welded design for durability and long life
- Picking list holder eliminates the need to handle loose papers
- 14-gauge steel shelves with 1 1/2" lip, configured up
- Two rigid and two swivel bolted 5" non-marking rubber casters
- Capacity: 1200 lbs. evenly distributed
- Durable Kleton blue enamel finish



MB442

| Model No. | Shelf Dimensions W" x D" | No. Shelves | Between Shelves" | Handle Height" | Overall Dimensions W" x D" x H" | Wt. lbs. |
|-----------|--------------------------|-------------|------------------|----------------|---------------------------------|----------|
| MB440 | 18 x 30 | 2 | 27 | 36 | 18 x 46 x 36 | 70 |
| MB441 | 24 x 36 | 2 | 27 | 36 | 24 x 52 x 36 | 80 |
| ML095 | 24 x 48 | 2 | 27 | 36 | 24 x 64 x 36 | 110 |
| MB442 | 18 x 30 | 3 | 12 | 36 | 18 x 46 x 36 | 85 |
| MB443 | 24 x 36 | 3 | 12 | 36 | 24 x 52 x 36 | 100 |
| ML096 | 24 x 48 | 3 | 12 | 36 | 24 x 64 x 36 | 120 |



CUSTOMISE IT TO YOUR SPECIFICATIONS.
SEE PAGE B71 FOR DETAILS

SERVICE & UTILITY CARTS

PLASTIC FLAT SHELF UTILITY SERVICE CART

- Durable structural foam construction will not dent, rust or bend
- Non-marking 4" casters
- Flat top shelf makes loading and unloading of heavy boxes easy
- Overall dimensions: 25 1/2" W x 40 1/2" L x 32 1/2" H
- Capacity: 500 lbs.

Model No. **ML620**



PLASTIC UTILITY SERVICE CARTS

- Durable structural foam construction will not dent, rust or bend
- Non-marking 4" casters
- Capacity: 500 lbs



ML619



ML618



| Model No. | Overall Dimensions | | | |
|-----------|--------------------|---|--------|----------|
| | W" | x | L" | H" |
| ML618 | 17 1/2 | x | 34 1/2 | x 32 1/2 |
| ML619 | 25 1/2 | x | 40 1/2 | x 32 1/2 |

LIGHT-DUTY UTILITY CARTS

- Durable plastic construction
- Comes with middle shelf and two convenient handles
- Shelves are flat with retaining beaded edges
- 4" swivel non-marking casters
- Platinum
- Assists in complying with HACCP guidelines



| Model No. | Shelf Dimensions | | | Capacity lbs. | Wt. lbs. |
|-----------|------------------|---|----|---------------|----------|
| | W" | x | H" | | |
| MH223 | 19 | x | 34 | 200 | 30 |

CART W/ENCLOSED END PANELS

| | | | | | | | |
|-------|----|---|----|---|--------|-----|----|
| MH829 | 18 | x | 31 | x | 37 1/2 | 300 | 37 |
|-------|----|---|----|---|--------|-----|----|



MH223

STANDARD/MEDIUM DUTY STAINLESS STEEL CARTS

- Durable chassis frame with protective bumpers on legs and handle
- Ideal for constant usage with light to moderate loads
- 1" edge on three sides of top and middle shelves
- All edges down on bottom shelf
- All rubber swivel casters standard



| Model No. | Shelf Dimensions | | | No. of Shelves | Overall Dimensions | | | Caster Dim." | Cap. lbs. | Wt. lbs. | |
|-----------|------------------|---|----|----------------|--------------------|---|--------|--------------|-----------|----------|----|
| | W" | x | L" | | W" | x | H" | | | | |
| MI812 | 15 1/2 | x | 24 | 3 | 16 1/4 | x | 27 1/2 | x 32 1/8 | 3 1/2 | 300 | 29 |
| MI813 | 18 | x | 27 | 3 | 18 3/8 | x | 30 3/4 | x 33 | 3 1/2 | 300 | 32 |
| MI816 | 15 1/2 | x | 24 | 3 | 16 3/4 | x | 27 5/8 | x 32 1/8 | 4 | 500 | 39 |
| MI817 | 18 | x | 27 | 3 | 19 | x | 31 | x 32 1/8 | 4 | 500 | 42 |
| MI818 | 21 | x | 35 | 3 | 22 3/8 | x | 39 1/4 | x 37 1/4 | 5 | 500 | 68 |



MI813

TRADES CARTS

- Use as mobile workbench
- Sized to hold large tools and supplies yet fits in tight spaces
- Four compartmentalised parts box and two versatile storage bins
- Mounting bracket to serve as an electrical cord wrap and convenient handle bin to keep small tools/parts
- Constructed of black plastic for lightness and durability
- 5" casters (two with brakes)
- Also available with a fully enclosed, lockable storage compartment
- 19 1/4" W x 38" L x 33 3/8" H
- Capacity: 180 lbs. (top shelf), 150 lbs. (bottom shelf)
- Assembly required

Model No. **MK744**

Trades Cart Wt.: 50 lbs.

Model No. **MK745**

Trades Cart w/Lockable Cabinet Wt.: 68 lbs



MK744



MK745

FLAT SHELF UTILITY CARTS

- Ergonomic handle design improves control and worker safety
- Flat design makes loading and unloading of heavy boxes and parts easier
- Easy to reach tool/accessory hooks and storage area enhances productivity and organization
- Top shelf perimeter channel retains small items
- Constructed from sturdy structural foam that will not rust, dent, chip nor splinter
- Two rigid and two swivel 5" non-marking TPR casters
- Assembly required



| Model No. | Dimensions W" x L" x H" | Capacity lbs. | Wt. lbs. | |
|-----------|-------------------------|--------------------------|----------|-------|
| | | | | Black |
| ML456 | ML457 | 17 1/4 x 38 1/2 x 38 1/4 | 500 | 33 |
| ML458 | ML459 | 25 7/8 x 43 7/8 x 33 1/4 | 500 | 42 |
| ML460 | ML461 | 25 1/4 x 54 x 38 | 750 | 52 |

Note: Other sizes and accessories available



ML456

HEAVY-DUTY UTILITY CARTS

- Ergonomic handle design improves control and worker safety
- Easy to reach tool/accessory hooks and storage area enhances productivity and organization
- 2 3/4" deep top shelf securely holds contents
- Constructed from sturdy structural foam that will not rust, dent, chip nor splinter
- Two rigid and two swivel casters
- Assembly required



| Model No. | Caster Type | Dimensions W" x L" x H" | Capacity lbs. | Wt. lbs. | |
|-----------|-------------|-------------------------|--------------------------|----------|-------|
| | | | | | Black |
| ML448 | ML449 | 5" Non-Marking TPR | 17 7/8 x 39 x 33 1/4 | 500 | 31 |
| ML450 | ML451 | 5" Non-Marking TPR | 25 7/8 x 45 1/4 x 33 1/4 | 500 | 44 |
| ML452 | - | 8" Pneumatic | 25 7/8 x 45 1/4 x 37 1/8 | 500 | 66 |
| ML453 | - | 5" Non-Marking TPR | 26 x 55 x 33 1/4 | 750 | 52 |
| ML455 | - | 8" Pneumatic | 26 x 55 x 33 1/4 | 750 | 74 |

Note: Other sizes and accessories available



ML448

WIRE MESH STOCK CARTS

WIRE MESH UTILITY CARTS

- Rugged all-welded steel construction ready to use
- Designed for efficient loading/unloading and transportation of merchandise
- 14-gauge steel shelves, 1 1/2" lip up
- Frame constructed from 1 1/2" angle iron and 2" x 2" wire mesh

- **Includes:** Two rigid and two swivel 5" or 6" bolted-on casters
- Capacity: 1200-2400 lbs. evenly distributed
- Durable Kleton blue enamel finish

| 5" Non-Marking Rubber 1200-lb. Cap. Model No. | 6" Polyurethane 2400-lb. Cap. Model No. | Base W" x L" | Inside Wall Height" | Handle Height" | Clearance Between Shelves" | Overall Dimensions W" x L" x H" | Wt. lbs. |
|---|---|-----------------|---------------------------|-------------------|----------------------------------|---------------------------------------|-------------|
| TWO-SIDED, TWO SHELVES | | | | | | | |
| ML162 | ML168 | 24 x 36 | 55 | 42 | 26 | 24 x 39 x 63 | 95 |
| ML163 | ML169 | 24 x 48 | 55 | 42 | 26 | 24 x 51 x 63 | 112 |
| ML164 | ML170 | 24 x 60 | 55 | 42 | 26 | 24 x 63 x 63 | 127 |
| ML165 | ML171 | 30 x 48 | 55 | 42 | 26 | 30 x 51 x 63 | 129 |
| ML166 | ML172 | 30 x 60 | 55 | 42 | 26 | 30 x 63 x 63 | 144 |
| ML167 | ML173 | 30 x 72 | 55 | 42 | 26 | 30 x 75 x 63 | 167 |
| TWO-SIDED, THREE SHELVES | | | | | | | |
| ML174 | ML180 | 24 x 36 | 55 | 42 | 16 1/2 | 24 x 39 x 63 | 120 |
| ML175 | ML181 | 24 x 48 | 55 | 42 | 16 1/2 | 24 x 51 x 63 | 137 |
| ML176 | ML182 | 24 x 60 | 55 | 42 | 16 1/2 | 24 x 63 x 63 | 152 |
| ML177 | ML183 | 30 x 48 | 55 | 42 | 16 1/2 | 30 x 51 x 63 | 154 |
| ML178 | ML184 | 30 x 60 | 55 | 42 | 16 1/2 | 30 x 63 x 63 | 169 |
| ML179 | ML185 | 30 x 72 | 55 | 42 | 16 1/2 | 30 x 75 x 63 | 192 |
| THREE-SIDED, ONE SHELF | | | | | | | |
| ML220* | ML190* | 24 x 36 | 55 | 42 | - | 24 x 39 x 63 | 102 |
| ML221* | ML191* | 24 x 48 | 55 | 42 | - | 24 x 51 x 63 | 110 |
| ML222* | ML192* | 24 x 60 | 55 | 42 | - | 24 x 63 x 63 | 120 |
| ML223* | ML193* | 30 x 48 | 55 | 42 | - | 30 x 51 x 63 | 135 |
| ML224* | ML194* | 30 x 60 | 55 | 42 | - | 30 x 63 x 63 | 145 |
| ML225* | ML195* | 30 x 72 | 55 | 42 | - | 30 x 75 x 63 | 155 |
| THREE-SIDED, TWO SHELVES | | | | | | | |
| ML196 | ML202 | 24 x 36 | 55 | 42 | 26 | 24 x 39 x 63 | 127 |
| ML197 | ML203 | 24 x 48 | 55 | 42 | 26 | 24 x 51 x 63 | 142 |
| ML198 | ML204 | 24 x 60 | 55 | 42 | 26 | 24 x 63 x 63 | 159 |
| ML199 | ML205 | 30 x 48 | 55 | 42 | 26 | 30 x 51 x 63 | 182 |
| ML200 | ML206 | 30 x 60 | 55 | 42 | 26 | 30 x 63 x 63 | 192 |
| ML201 | ML207 | 30 x 72 | 55 | 42 | 26 | 30 x 75 x 63 | 211 |
| THREE-SIDED, THREE SHELVES | | | | | | | |
| ML208 | ML214 | 24 x 36 | 55 | 42 | 16 1/2 | 24 x 39 x 63 | 152 |
| ML209 | ML215 | 24 x 48 | 55 | 42 | 16 1/2 | 24 x 51 x 63 | 174 |
| ML210 | ML216 | 24 x 60 | 55 | 42 | 16 1/2 | 24 x 63 x 63 | 198 |
| ML211 | ML217 | 30 x 48 | 55 | 42 | 16 1/2 | 30 x 51 x 63 | 229 |
| ML212 | ML218 | 30 x 60 | 55 | 42 | 16 1/2 | 30 x 63 x 63 | 239 |
| ML213 | ML219 | 30 x 72 | 55 | 42 | 16 1/2 | 30 x 75 x 63 | 267 |

* Base shelf only

SECURITY TRUCKS

- Rugged all-welded steel construction, ready to use
- Designed for efficient loading/unloading and transportation of merchandise
- 14-gauge steel shelves, 1 1/2" lip up
- Frame constructed from 1 1/2" angle iron and 2" x 2" wire mesh

- **Includes:** Two rigid and two swivel 5" or 6" bolted-on casters
- Comes with hasp for padlock
- Capacity: 1200-2400 lbs. evenly distributed
- Durable Kleton blue enamel finish

| 5" Non-Marking Rubber 1200-lb. Cap. Model No. | 6" Polyurethane 2400-lb. Cap. Model No. | Base W" x L" | Inside Wall Height" | Handle Height" | Clearance Between Shelves" | Overall Dimensions W" x L" x H" | Wt. lbs. |
|---|---|-----------------|---------------------------|-------------------|----------------------------------|---------------------------------------|-------------|
| TWO SHELVES | | | | | | | |
| ML238 | ML244 | 24 x 36 | 55 | 42 | 25 | 26 x 39 x 62 1/2 | 157 |
| ML239 | ML245 | 24 x 48 | 55 | 42 | 25 | 26 x 51 x 62 1/2 | 172 |
| ML241 | ML247 | 30 x 48 | 55 | 42 | 25 | 32 x 51 x 62 1/2 | 212 |
| ML242 | ML248 | 30 x 60 | 55 | 42 | 25 | 32 x 63 x 62 1/2 | 222 |
| ML243 | ML249 | 30 x 72 | 55 | 42 | 25 | 32 x 75 x 62 1/2 | 241 |
| THREE SHELVES | | | | | | | |
| ML250 | ML256 | 24 x 36 | 55 | 42 | 16 | 26 x 39 x 62 1/2 | 182 |
| ML251 | ML257 | 24 x 48 | 55 | 42 | 16 | 26 x 51 x 62 1/2 | 204 |
| ML253 | ML259 | 30 x 48 | 55 | 42 | 16 | 32 x 51 x 62 1/2 | 259 |
| ML254 | ML260 | 30 x 60 | 55 | 42 | 16 | 32 x 63 x 62 1/2 | 269 |
| ML255 | ML261 | 30 x 72 | 55 | 42 | 16 | 32 x 75 x 62 1/2 | 297 |

BOX TRUCKS

- Rugged all-welded steel construction, ready to use
- Contain and transport small bulk parts or materials in your plant or warehouse
- Frame constructed from 1 1/2" angle iron construction and 2" x 2" wire mesh

- **Includes:** Two rigid and two swivel 5" non-marking bolted-on rubber casters
- Capacity: 1200 lbs. evenly distributed
- Durable Kleton blue enamel finish

| Model No. | Base W" x L" | Inside Wall Height" | Handle Height" | Overall Dim. W" x L" x H" | Wt. lbs. |
|-----------|--------------|---------------------|----------------|---------------------------|----------|
| MB672 | 24 x 36 | 24 | 30 | 24 x 39 x 31 1/2 | 62 |
| ML186 | 24 x 48 | 24 | 30 | 24 x 51 x 31 1/2 | 75 |
| ML187 | 24 x 60 | 24 | 30 | 24 x 63 x 31 1/2 | 85 |

| Model No. | Base W" x L" | Inside Wall Height" | Handle Height" | Overall Dim. W" x L" x H" | Wt. lbs. |
|-----------|--------------|---------------------|----------------|---------------------------|----------|
| ML188 | 30 x 48 | 24 | 30 | 30 x 51 x 31 1/2 | 86 |
| MB680 | 30 x 60 | 24 | 30 | 30 x 63 x 31 1/2 | 95 |
| ML189 | 30 x 72 | 24 | 30 | 30 x 75 x 31 1/2 | 107 |

CUSTOMISE IT TO YOUR SPECIFICATIONS. SEE PAGE B71 FOR DETAILS



ML163



ML200



ML254



CASTERS

GENERAL USE CASTERS

POLYOLEFIN CASTERS

- Rolls easily and quietly on all floors
- Lightweight and economical
- Non-marking, easy to maintain, steam cleanable
- High impact strength
- Superior resistance to most oils, chemicals, grease and acids

Applications:

For food service equipment, mobile warehouse equipment, factories and abusive environments.

Plate dimensions: 2 5/8" x 3 3/4"
Bolt hole centres: 1 3/4" x 2 7/8"
Bolt hole dimension: 5/16"



ML391



| Model No. | Wheel Dia." | Caster Type | Capacity lbs. | Tread Width" | Overall Height" |
|-----------|-------------|-------------|---------------|--------------|-----------------|
| ML391 | 3 | Swivel | 250 | 1 1/4 | 4 1/2 |
| ML392 | 3 | Rigid | 250 | 1 1/4 | 4 1/2 |
| ML393 | 4 | Swivel | 250 | 1 1/4 | 5 1/4 |
| ML394 | 4 | Rigid | 250 | 1 1/4 | 5 1/4 |
| ML395 | 5 | Swivel | 250 | 1 1/4 | 6 1/8 |
| ML396 | 5 | Rigid | 250 | 1 1/4 | 6 1/8 |

POLYURETHANE CASTERS

- Smooth rolling, low noise operation
- Non-marking, cut and tear resistant
- Die cast aluminum core with brown polyurethane tread
- Resistant to most chemicals, moisture friendly
- Double ball raceway
- Annular ball bearing
- Brake type: Total locking

Applications:

Food service equipment, factory use, mobile warehouse equipment.



ML045

ML441



| | | |
|---|---|--|
| Plate dimensions: 3 = 2 5/8" x 3 3/4" 4 = 3 1/8" x 4 1/8" 4 HD = 4" x 4 1/2" 5 = 4" x 4 1/2" 6 = 4" x 4 1/2" 8 = 4" x 4 1/2" | Bolt hole centres: 3 = 1 3/4" x 2 3/4" 4 = 2 3/8" x 3 1/16" 4 HD = 3 1/4" x 2 3/4" 5 = 3 1/4" x 2 3/4" 6 = 3 1/4" x 2 3/4" 8 = 3 1/4" x 2 3/4" | Bolt hole dimension: 3 = 5/16" 4 = 5/16" 4 HD = 3/8" 5 = 3/8" 6 = 3/8" 8 = 3/8" |
|---|---|--|

| Model No. | Wheel Dia." | Caster type | Capacity lbs. | Thread Width" | Overall Height" |
|-----------|-------------|----------------------|---------------|---------------|-----------------|
| ML044 | 3 | Swivel | 230 | 1 1/4 | 4 1/4 |
| ML043 | 3 | Rigid | 230 | 1 1/4 | 4 1/4 |
| ML045 | 4 | Swivel | 440 | 1 1/2 | 5 3/8 |
| ML046 | 4 | Rigid | 440 | 1 1/2 | 5 3/8 |
| ML441 | 4HD | Swivel | 550 | 1 5/8 | 5 5/8 |
| ML442 | 4HD | Rigid | 550 | 1 5/8 | 5 5/8 |
| MN264 | 4HD | Total locking brake | 550 | 1 5/8 | 5 5/8 |
| ML397 | 5 | Swivel | 650 | 1 1/2 | 6 1/2 |
| ML398 | 5 | Rigid | 650 | 1 1/2 | 6 1/2 |
| MN265 | 5 | Total Locking Brake | 650 | 1 1/2 | 6 1/2 |
| ML399 | 6 | Swivel | 850 | 1 1/2 | 7 1/2 |
| ML400 | 6 | Rigid | 850 | 1 1/2 | 7 1/2 |
| MN266 | 6 | Total Locking Brake | 850 | 1 1/2 | 7 1/2 |
| MN449 | 6 | Butterfly Side Brake | 850 | 1 1/2 | 7 1/2 |
| ML401 | 8 | Swivel | 1000 | 1 5/8 | 9 1/2 |
| ML402 | 8 | Rigid | 1000 | 1 5/8 | 9 1/2 |
| MN267 | 8 | Total Locking Brake | 1000 | 1 5/8 | 9 1/2 |
| MN450 | 8 | Butterfly Side Brake | 1000 | 1 5/8 | 9 1/2 |

BLUE ELASTIC RUBBER CASTERS

- High load capacity, rolls easily and quietly on all floors
- Non-marking, excellent floor protection
- Zinc-chromed plated finish provides corrosion resistance
- Elastic rubber tread rejects floor debris
- Sealed double ball raceway
- Tread guards
- Ball bearing
- Brake type: Total locking



ML333

Applications:

General duty applications in mobile warehouse equipment and factory use.

Plate dimensions: 3 3/8" x 4"
Bolt hole centres: 2 3/8" x 3 1/8"
Bolt hole dimension: 5/16"



| Model No. | Wheel Dia." | Caster Type | Capacity lbs. | Tread Width" | Overall Height" |
|-----------|-------------|----------------|---------------|--------------|-----------------|
| ML333 | 4 | Swivel | 350 | 1 3/8 | 5 |
| ML334 | 4 | Rigid | 350 | 1 3/8 | 5 |
| ML342 | 4 | Swivel w/Brake | 350 | 1 3/8 | 5 |
| ML337 | 5 | Swivel | 400 | 1 3/8 | 6 |
| ML338 | 5 | Rigid | 400 | 1 3/8 | 6 |
| ML345 | 5 | Swivel w/Brake | 400 | 1 3/8 | 6 |

MOLD-ON RUBBER CASTERS

- Molded rubber wheel permanently bonded to spoked cast iron core
- Iron centre gives it strength while the molded rubber offers smooth and quiet operation
- Protects loads and surfaces
- Won't damage warehouse or factory floors
- Brake type: Total locking

Surface Applications:

Concrete, brick, carpet, steel, tile, asphalt, wood and linoleum

Plate dimensions: 4" x 4 1/2"
Bolt hole centres: 2 7/8" x 3 1/3"
Bolt hole dimension: 7/16"



ML851



| Swivel Model No. | Rigid Model No. | Total Locking Brake Model No. | Butterfly Side Brake Model No. | Wheel Dia." | Capacity lbs. | Tread Width" |
|------------------|-----------------|-------------------------------|--------------------------------|-------------|---------------|--------------|
| ML846 | ML847 | -- | -- | 5 | 400 | 2 |
| ML849 | ML850 | ML851 | MN451 | 6 | 500 | 2 |
| ML852 | ML853 | ML854 | MN452 | 8 | 600 | 2 |

HI-TEMP NYLON CASTERS

- Smooth rolling, non-marking
- Zinc chrome plated finish provides corrosion resistance
- Superior resistance to most oils, chemicals, and grease
- Double ball raceway
- Ball bearing
- Total lock brake
- Maximum temperature 230°C

Surface Applications:

Concrete, brick, carpet and steel

Plate dimensions: 4" x 4 1/2"
Bolt hole centres: 3" x 3 1/3"
Bolt hole dimension: 7/16"



ML863



| Model No. | Wheel Dia." | Style | Capacity lbs. | Thread Width" | Overall Height" |
|-----------|-------------|----------------------|---------------|---------------|-----------------|
| ML861 | 6 | Swivel | 800 | 1 3/4 | 7 5/8 |
| ML862 | 6 | Rigid | 800 | 1 3/4 | 7 5/8 |
| ML863 | 6 | Total Locking Brake | 800 | 1 3/4 | 7 5/8 |
| MN453 | 6 | Butterfly Side Brake | 800 | 1 3/4 | 7 5/8 |
| ML864 | 8 | Swivel | 850 | 1 3/4 | 9 1/2 |
| ML865 | 8 | Rigid | 850 | 1 3/4 | 9 1/2 |
| ML866 | 8 | Total Locking Brake | 850 | 1 3/4 | 9 1/2 |
| MN454 | 8 | Butterfly Side Brake | 850 | 1 3/4 | 9 1/2 |

NYLON SANDWICH CASTERS

- Non-marking white nylon elastic rubber cushion ring layer reduces noise and vibration
- Chrome zinc-finish for corrosion resistance
- Double raceway
- Ball bearing
- Brake type: Total locking

Surface Applications:
Concrete, brick, carpet and steel



MN443

Plate dimensions: 3 1/3" x 4 1/8"
Bolt hole centres: 3 1/8" x 2 1/3"
Bolt hole dimension: 5/16"

| Model No. | Wheel Dia." | Caster Type | Capacity lbs. | Tread Width" | Overall Height" |
|-----------|-------------|----------------|---------------|--------------|-----------------|
| MN441 | 4 | Swivel | 440 | 1 3/8 | 5 1/8 |
| MN442 | 4 | Rigid | 440 | 1 3/8 | 5 1/8 |
| MN443 | 4 | Swivel w/Brake | 440 | 1 3/8 | 5 1/8 |
| MN444 | 5 | Swivel | 440 | 1 3/8 | 6 1/8 |
| MN445 | 5 | Rigid | 440 | 1 3/8 | 6 1/8 |
| MN446 | 5 | Swivel w/Brake | 440 | 1 3/8 | 6 1/8 |

PNEUMATIC CASTERS

- Four ply pneumatic casters offer smooth and quiet rolling over the roughest surfaces and outdoor terrain
- Shock absorbing properties give the greatest possible protection to both the load and floor
- The "Air cushion" feature will transport the most fragile material and instruments without damage
- Not recommended for floors with metal shavings or corrosive chemicals

Surface Applications:
Concrete, brick, carpet, steel, tile, asphalt, wood and linoleum

Plate dimensions: 4" x 4 1/2"
Bolt hole centres: 2 3/4" x 3 3/8"
Bolt hole dimension: 13/32"



MN221

MN222

| Model No. | Wheel Dia." | Caster Type | Capacity lbs. | Tread Width" | Overall Height" |
|-----------|-------------|-------------|---------------|--------------|-----------------|
| MN222 | 8 | Swivel | 350 | 2 | 10 |
| MN221 | 8 | Rigid | 350 | 2 | 10 |
| MN224 | 10 | Swivel | 400 | 3 | 12 |
| MN223 | 10 | Rigid | 400 | 3 | 12 |

For optimum use pneumatic wheels must be properly inflated

ENVIROTHANE™ WHEELS

- Solid non-marking polyurethane used for high load capacities
- Harder than soft rubber and softer than hard rubber
- Top quality wheel that will not damage your floors and will not develop flat spots under standing loads
- Government approved
- Temperature: -43°C to 110°C
- Durometer: 45 - 65 D Scale

- Excellent for:**
- Platform trucks
 - Food service equipment
 - Hotel equipment
 - Small waste bins
 - Large stock trucks
 - Factory use
 - Textile carts
 - Abusive applications



| Model No. | Wheel Dia." | Bearing Type | Cap. lbs. | Tread Width" | Hub Length" | Bearing Bore" |
|-----------|-------------|--------------|-----------|--------------|-------------|---------------|
| MG534 | 3 | Nylon/Steel | 100 | 7/8 | 1 | 5/16 |
| MG535 | 3 | Nylon | 150 | 1 | 1 3/8 | 5/16 |
| MG536 | 3 | Nylon | 250 | 1 1/4 | 1 5/8 | 5/16 |
| MG537 | 4 | Nylon | 150 | 1 | 1 3/8 | 5/16 |
| MG538 | 4 | Nylon | 250 | 1 1/4 | 1 5/8 | 5/16 |
| MG539 | 4 | Plain | 500 | 1 1/2 | 1 3/4 | 3/8 |
| MG540 | 4 | Roller | 650 | 2 | 2 3/16 | 1/2 |

THERMOPLASTIC CASTERS

- Heavy-duty double swivel raceway
- Grey thermoplastic rubber is non-marking and includes synthetic tread guards to protect roller bearings
- Durable zinc-plated pressed steel assembly for durability



ML017

Plate dimensions: 3 1/2" x 2 1/2"
Bolt hole centres: 2 3/4" x 1 3/4" centre-to-centre
Bolt hole dimension: 5/16"

| Model No. | Wheel Dia." | Caster Type | Capacity lbs. | Tread Width" | Overall Height" | Bearing Type |
|-----------|-------------|----------------|---------------|--------------|-----------------|--------------|
| ML014 | 3 1/8 | Swivel | 130 | 1 1/4 | 4 1/4 | Ball |
| ML020 | 3 1/8 | Rigid | 130 | 1 1/4 | 4 1/4 | Ball |
| ML017 | 3 1/8 | Swivel w/Brake | 130 | 1 1/4 | 4 1/4 | Ball |
| ML015 | 4 | Swivel | 200 | 1 1/8 | 5 1/4 | Ball |
| ML021 | 4 | Rigid | 200 | 1 1/8 | 5 1/4 | Ball |
| ML018 | 4 | Swivel w/Brake | 200 | 1 1/8 | 5 1/4 | Ball |
| ML016 | 5 | Swivel | 220 | 1 1/8 | 6 1/4 | Ball |
| ML022 | 5 | Rigid | 220 | 1 1/8 | 6 1/4 | Ball |
| ML019 | 5 | Swivel w/Brake | 220 | 1 1/8 | 6 1/4 | Ball |

FLAT-FREE CASTERS

- Solid polyurethane wheel never runs flat
- Same bounce feel and weight of a pneumatic caster
- Smooth and quiet rolling over rough terrain and surfaces
- Less costly than traditional foam-filled tires
- Ball bearing

Surface Applications:
Concrete, brick, carpet, steel, tile, asphalt, wood and linoleum

Plate dimensions: 4" x 4 1/2"
Bolt hole centres: 2 3/4" x 3 3/8"
Bolt hole dimension: 13/32"



MN226

MN225

| Model No. | Wheel Dia." | Caster Type | Capacity lbs. | Tread Width" | Overall Height" |
|-----------|-------------|-------------|---------------|--------------|-----------------|
| MN226 | 8 | Swivel | 275 | 2 | 10 |
| MN225 | 8 | Rigid | 275 | 2 | 10 |
| MN228 | 10 | Swivel | 300 | 3 | 12 |
| MN227 | 10 | Rigid | 300 | 3 | 12 |

WHEELS

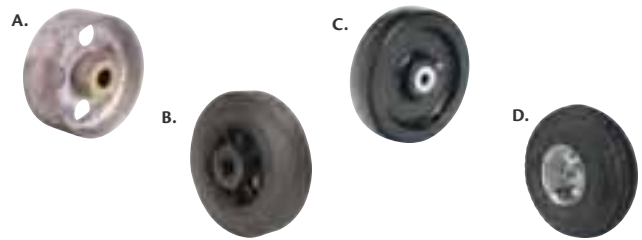

| Model No. | Wheel Dia." | Bearing Type | Cap. lbs. | Tread Width" | Bearing Bore" | Wheel Type |
|-----------|-------------|--------------|-----------|--------------|---------------|------------|
| A. MC298 | 5 | Roller | 1500 | 2 | 3/4 | Cast Iron |
| B. MH296 | 6 | Roller | 400 | 1 1/2 | 3/4 | Rubber |
| B. MH297 | 8 | Roller | 595 | 2 | 3/4 | Rubber |
| B. MH298 | 10 | Roller | 400 | 2 | 3/4 | Rubber |
| C. MC337 | 8 | Roller | 1000 | 2 | 3/4 | Phenolic |
| C. MC340 | 12 | Roller | 3000 | 2 1/2 | 1 | Phenolic |
| D. ML069 | 10 | Ball | 350 | 3 1/2 | 3/4 | Pneumatic |

WHEEL CHOCKS

RUBBER WHEEL CHOCKS

- Highly resistant to abrasion, impacts, corrosion, sun, salt, ozone and oil
- Steel ring on back
- 9 1/2" L x 6 1/2" W x 8 1/2" H
- Weight: 11 lbs.

Model No. KH032



LAMINATED RUBBER CHOCKS

- Designed to fit curvature of tire for a strong grip
- Extra heavy-duty laminated rubber and steel construction for use with heavy utility trucks and equipment
- Load capacity: Up to 40000 lbs.



| Model No. | Approximate Dimensions L" x W" x H" | Wt. lbs. |
|-----------|--|----------|
| KH603 | 8 x 8 x 8 | 14 |

RUBBER WHEEL CHOCKS

- Constructed of reinforced rubber
- Resists tearing, abrasions, impacts, corrosion, sun, salt, and oil
- Handle on back for easy placement
- 9 7/8" L x 7 1/8" W x 7 1/2" H
- Weight: 9.5 lbs.

Model No. KH893



RUBBER CHOCKS

Fabricated of a tough rubber compound, reinforced for maximum wearability and strength.



| Model No. | Type | Approximate Dimensions L" x W" x H" | Wt. lbs. |
|-----------|---------|--|----------|
| KH600 | Handle | 9 x 8 x 6 | 10 |
| KH601 | Eyebolt | 9 x 8 x 6 | 10 |

ICE CHOCKS

- Formed steel
- "Tooth" like bottom assures reliable grip
- Lightweight and dependable
- Maximum holding power for snow and ice
- Overall dimensions: 10 1/2" L x 8" W x 9 1/4" H
- Powder-coated safety yellow finish for high visibility

Model No. KH964



URETHANE WHEEL CHOCKS

- Safety orange for greater visibility
- Molded-in hole through width of chock for attaching security chain (chain sold separately)
- Overall dimensions: 11" L x 8" W x 8" H

Model No. KH897

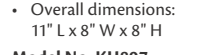

IRON WHEEL CHOCKS

- Suited for your toughest jobs



KH799



KH951

| Model No. | Chock Material | Dimensions L" x W" x H" | Colour | Wt. lbs. |
|-----------|----------------|----------------------------|---------------|----------|
| KH799 | Ductile Iron | 12 x 8 x 9 | Blue | 19 |
| KH951 | Ductile Iron | 7 1/4 x 8 1/2 x 8 1/2 | Safety Yellow | 14 |

ALUMINUM WHEEL CHOCKS

- High in strength but lightweight
- Resists the effects of oil, salt, corrosion and weather
- Non-sparking



KH023

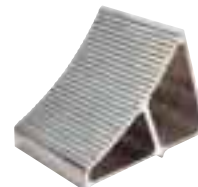

KH022

| Model No. | Dimensions L" x W" x H" | Wt. lbs. |
|-----------|----------------------------|----------|
| KH023 | 6 x 7 x 6 | 4 |
| KH022 | 7 x 10 3/4 x 8 | 7 |

WHEEL CHOCK ACCESSORIES

SECURITY CHAINS

- 18' steel chain attaches chock to dock
- Prevents misplacement, theft
- Zinc plated for corrosion resistance
- Diameter: 0.14 (3 mm)
- Working load limit: 255 lbs. (116 kg)
- Comes with hook
- Weight: 4 lbs.

Model No. KH027

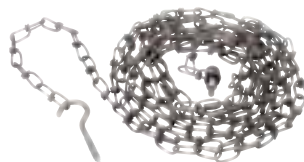

CAUTION SIGNS

- 10" x 14"
- Black letters on yellow background
- Material: Vinyl
- Weight: 6 oz.

Model No. SAT137 English

Model No. SEE554 French



WHEEL CHOCK WALL BRACKETS

- Prevents loss of chock
- Fits chocks up to 10" wide
- Sturdy yellow metal construction

Model No. KH963



RAIL CHOCKS

- These rugged steel rail chocks provide an effective means of blocking railcars for safe loading and unloading
- Steel points on chock heads bite into rail to prevent sliding. Standard finish in railroad maintenance yellow
- Integral 7 1/2" x 9 1/2" sign reads "chock"
- Single rail chock for stoppage in one direction; double rail chock for stoppage in both directions (with rubber strap and hooks for greater tension)
- Choice of exposed (above ground) or flush (level with ground) chocks

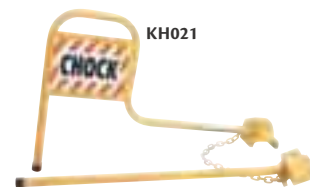

KH021



KH015

| Model No. | Description | Wt. lbs. |
|------------------|--------------|----------|
| FOR EXPOSED RAIL | | |
| KH016 | Single Chock | 12 |
| KH021 | Double Chock | 16 |
| FOR FLUSH RAIL | | |
| KH015 | Single Chock | 12 |
| KH020 | Double Chock | 16 |

WHEEL CHOCK REFERENCE GUIDE

Select a wheel chock based on the gross operating weight and tire diameter of the vehicle.



TIRE DIAMETER RANGE

| | Up to 32" Dia. | Up to 35" Dia. | Up to 38" Dia. | Up to 46" Dia. | Up to 65" Dia. | Up to 95" Dia. | Up to 105" Dia. | Up to 142" Dia. | Up to 165" Dia. | |
|--------------------------------|--------------------|----------------|----------------|-------------------------|-------------------------|----------------|-----------------|-----------------|-----------------|-------|
| GROSS VEHICLE OPERATING WEIGHT | Up to 30,000 lbs. | KH971 KH966 | KH971 | KH968 | KH968 | KH977 | KH025 | KH978 | — | — |
| | Up to 40,000 lbs. | KH970 KH967 | KH970 | KH969 | KH969 | KH977 | KH025 | KH978 | — | — |
| | Up to 50,000 lbs. | KH967 | KH968 | KH969 | KH969 | KH977 | KH025 | KH978 | — | — |
| | Up to 60,000 lbs. | KH968 KH967 | KH968 | KH969 KH792 KH973 | KH969 KH974 KH975 | KH977 | KH025 | KH978 | — | — |
| | Up to 70,000 lbs. | KH969 | KH969 | KH972 KH973 | KH974 KH975 | KH977 | KH025 | KH978 | — | — |
| | Up to 80,000 lbs. | KH792 KH973 | KH792 KH973 | KH792 KH973 | KH974 KH975 | KH977 | KH025 | KH978 | — | — |
| | Up to 150,000 lbs. | — | — | — | KH974 KH975 | KH977 | KH025 | KH978 | KH980 | KH979 |
| | Up to 245,000 lbs. | — | — | — | KH977 | KH977 | KH025 | KH978 | KH980 | KH979 |
| | Up to 366,000 lbs. | — | — | — | — | KH025 | KH025 | KH978 | KH980 | KH979 |
| | Up to 550,000 lbs. | — | — | — | — | KH978 | KH978 | KH978 | KH980 | KH979 |
| | Up to 855,000 lbs. | — | — | — | — | KH980 | KH980 | KH980 | KH980 | KH979 |
| Up to 1,600,000 lbs. | — | — | — | — | KH979 | KH979 | KH979 | KH979 | KH979 | |

Note: A minimum of four wheel chocks must be used for gross vehicle operating weights from 855,000 - 1,600,000 lbs

GENERAL PURPOSE POLYURETHANE WHEEL CHOCKS

- Durable polyurethane construction
- Ideal for use with over-the-road trucks, trailers, pickups and utility vehicles
- Resistant to oils, fuels and solvents
- Easy-grip carrying handle
- Eyebolt for ropes or chains
- High visibility orange



KH966

| Model No. | Mfg. No. | Overall Dimensions | | | Wt. lbs. |
|-----------|------------|--------------------|-------|-------|----------|
| | | L" | W" | H" | |
| KH966 | UC1400-4.5 | 10 | 8 1/2 | 5 | 4.5 |
| KH967 | UC1400-6 | 10 | 8 1/2 | 5 | 6 |
| KH968 | UC1500-4.5 | 11 1/2 | 9 | 8 1/2 | 4.5 |
| KH969 | UC1500-6 | 11 1/2 | 9 | 8 1/2 | 6 |
| KH970 | UC1600 | 11 1/4 | 8 | 8 1/4 | 3.5 |
| KH971 | UC1700 | 8 1/2 | 7 1/2 | 6 1/4 | 2 |

HEAVY-DUTY POLYURETHANE WHEEL CHOCKS

- Durable polyurethane construction
- Ideal for use with ground vehicles and heavy equipment
- Resistant to oils, fuels and solvents
- Easy-grip carrying handle
- Mounting hole for ropes, chains or brackets
- Overall Dimensions: 17" L x 14" W x 14" H
- High visibility orange
- Weight: 25 lbs.



KH025

Model No. KH025
Mfg. No. MC1210

ALL-TERRAIN HEAVY-DUTY POLYURETHANE WHEEL CHOCKS

- Durable polyurethane construction
- Ideal for use with underground mining equipment, fire fighting and large utility vehicles
- Resistant to oils, fuels and solvents
- Easy-grip carrying handle
- Includes replaceable aluminum traction cleats or rubber pads
- Safety yellow

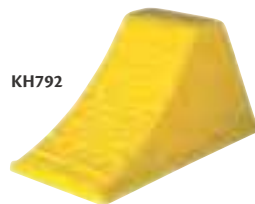

KH792

| Model No. | Mfg. No. | Overall Dimensions | | | Base Configuration | Wt. lbs. |
|-----------|-----------|--------------------|--------|--------|--------------------|----------|
| | | L" | W" | H" | | |
| KH792 | AT3512-AC | 15 1/2 | 8 1/2 | 8 1/4 | Aluminum Ice Cleat | 7.1 |
| KH973 | AT3512-RP | 15 1/2 | 8 1/2 | 8 1/4 | Rubber Pad | 7.1 |
| KH974 | AT3514-AC | 21 | 11 1/4 | 12 1/4 | Aluminum Ice Cleat | 16.5 |
| KH975 | AT3514-RP | 21 | 11 1/4 | 12 1/4 | Rubber Pad | 16.1 |

HEAVY-DUTY POLYURETHANE WHEEL CHOCKS

- Durable polyurethane construction
- Ideal for use with ground vehicles and heavy equipment
- Resistant to oils, fuels and solvents
- Easy-grip carrying handle
- Mounting hole for ropes, chains or brackets
- Includes replaceable rubber pads
- Optional studs available for increased traction on snow and ice
- Safety yellow



KH977

| Model No. | Mfg. No. | Overall Dimensions | | | Wt. lbs. |
|-----------|----------|--------------------|---------|--------|----------|
| | | L" | W" | H" | |
| KH977 | MC3009 | 15 | 15 1/10 | 11 | 14.5 |
| KH978 | MC3010 | 17 7/10 | 15 1/2 | 10 | 19 |
| KH979 | MC3011 | 24 3/5 | 14 1/2 | 16 | 32 |
| KH980 | MC3012 | 21 9/10 | 14 9/10 | 10 3/5 | 23.75 |

CABLE PROTECTION

MODULAR CABLE & HOSE PROTECTION SYSTEMS

FEATURES:

- Polyurethane construction, non-conductive material
- 36" length per lineal protector
- Five bar tread plate surface
- Safety warning symbols molded into protector
- Modular interlocking design
- Recessed carrying handle
- Patented T-Connectors to extend to any length
- Universal safety colours

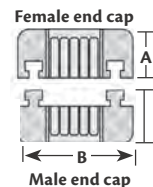
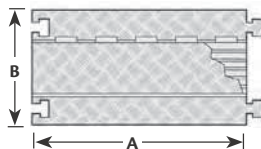

T-connector systems

BENEFITS:

- Weather and abrasion resistant; high load-bearing capacity
- Insulates electrical cables from human contact
- Increases traction
- Lightweight; easy to transport, set-up, breakdown, and store; multi-length applications
- Allows for moving with ease
- High visibility



KH699



KH700



KH702

CHECKERS
INDUSTRIAL SAFETY PRODUCTS, INC.

| Model No. | Description | A L" | B W" | C H" | D Channel W" | E Channel H" | Max. Load lbs. per tire at 21°C | Wt. lbs. |
|-----------------------------------|------------------------------------|-------|--------|---------|--------------|--------------|---------------------------------|----------|
| EXTRA HEAVY-DUTY | | | | | | | | |
| KH687 | 5-Channel Protector | 36 | 20 | 2 5/16 | 1 1/4 | 1 1/4 | 20150 | 25 |
| KH688 | 5-Channel End Caps (Female) | 7 1/2 | 20 | 2 5/16 | 1 1/4 | 1 1/4 | 20150 | 3.5 |
| | 5-Channel End Caps (Male) | 5 1/4 | 20 | 2 5/16 | 1 1/4 | 1 1/4 | 20150 | 3.5 |
| KH691 | 4-Channel Protector | 36 | 20 | 2 5/16 | 1 5/8 | 1 1/4 | 20150 | 26 |
| KH692 | 4-Channel End Caps (Female) | 7 1/2 | 20 | 2 5/16 | 1 5/8 | 1 1/4 | 20150 | 3.5 |
| | 4-Channel End Caps (Male) | 5 1/4 | 20 | 2 5/16 | 1 5/8 | 1 1/4 | 20150 | 3.5 |
| KH695 | 3-Channel Protector | 36 | 20 | 3 1/16 | 2 1/4 | 2 1/4 | 14210 | 28 |
| KH696 | 3-Channel End Caps (Female) | 8 1/4 | 20 | 3 1/16 | 2 1/4 | 2 1/4 | 14210 | 4 |
| | 3-Channel End Caps (Male) | 6 | 20 | 3 1/16 | 2 1/4 | 2 1/4 | 14210 | 4 |
| KH699 | 2-Channel Protector | 36 | 22 | 4 1/8 | 3 1/4 | 3 1/4 | 10880 | 33 |
| HEAVY-DUTY GENERAL PURPOSE | | | | | | | | |
| KH700 | 5-Channel Protector | 36 | 17 1/4 | 1 15/16 | 1 5/16 | 1 5/16 | 10500 | 22 |
| KH701 | 5-Channel End Caps (Female & Male) | 4 3/4 | 17 1/4 | 1 15/16 | 1 5/16 | 1 5/16 | 10500 | 2.7 |
| KH702 | 1-Channel Protector | 36 | 11 1/2 | 1 5/8 | 1 1/4 | 1 1/4 | 11700 | 13 |

LIGHT-DUTY SYSTEMS

- Gripper® connector system
- Made from tough, high impact absorbing, non-conductive polyurethane
- Resistant to oil, fuels and lubricants
- Recessed carrying handle molded in to the underside of the protector
- Capacity: 5000 lbs. per tire at 21°C
- Colours: grey and safety yellow

CHECKERS
INDUSTRIAL SAFETY PRODUCTS, INC.



KH981



Gripper® connector system

| Model No. | Description | Overall Dimensions | | | Channel Dimensions | | Wt. lbs. |
|-----------|---------------------|--------------------|--------|-------|--------------------|-------|----------|
| | | L" | W" | H" | Dia." | H" | |
| KH981 | 5-Channel Protector | 36 | 16 4/9 | 1 3/5 | 1 1/4 | 1 1/4 | 12.75 |
| KH986 | 3-Channel Protector | 36 | 18 1/5 | 2 2/3 | 2 1/4 | 2 1/4 | 23 |

INDUSTRIAL CORD COVERS

- Protect your cables from foot and vehicular traffic
- Constructed from non-conductive vulcanized rubber
- Suitable for indoor and outdoor use
- Withstands car and light truck traffic up to 5000 lbs. per axle
- Stronger and longer lasting than PVC covers
- Excellent in temperatures from -40°C to 150°C
- Black with yellow safety stripe



LIND **E** EQUIPMENT

| 5' Order No. | 10' Order No. | Description | W" | H" | Channel W" | Channel H" |
|--------------|---------------|-------------|-------|-------|------------|------------|
| KH907 | KH908 | 1 Channel | 3 1/4 | 3/4 | 3/4 | 1/2 |
| KH909 | KH910 | 1 Channel | 3 | 1 | 1 | 3/4 |
| KH911 | KH912 | 2 Channels | 5 1/2 | 1 1/8 | 7/8 | 3/4 |
| KH913 | - | 1 Channel | 6 | 1 7/8 | 1 1/2 | 1 1/2 |

TRAILER STABILIZING JACKS

- Keeps tractorless trailers leveled while being loaded or unloaded
- Prevents accidents if wheel support collapses
- Stabilizes vehicle against load shifts
- Lowered height: 39 1/2"
- Raised height: 51"
- Removeable 37 1/2" positioning and ratcheting handle
- 8" diameter support pad
- 8" wheels
- 100000-lb. supporting capacity each and 40000-lb. lifting capacity
- Recommended use in pairs**
- 1-year warranty**

Model No. KH777

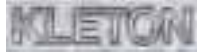

AUTO STAND TRAILER STABILIZING JACKS

- Heavy gauge steel construction
- Large base pad (17" x 18 1/2")
- Gas activated, self levelling system
- 10" diameter semi-pneumatic rubber tires for easy handling
- 41"- 50 1/2" height range
- Large trailer contact pad
- Capacity: 100 000 lbs.
- Only one required per trailer
- 1-year warranty**

Model No. KH791



MOLDED DOCK BUMPERS

- Protects building and dock areas
- Shockproof, tear and freeze resistant

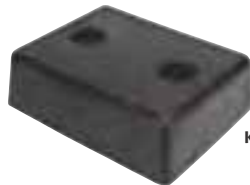

KH005



| Model No. | Type | Face Dim. W" x H" | Overall Projection" | Wt. lbs. |
|-----------|-------------|-------------------|---------------------|----------|
| KH005 | Rectangular | 13 x 10 | 4 | 16 |
| KH009 | Rectangular | 18 x 10 | 4 | 32 |

EXTRUDED RUBBER DOCK FENDERS

D-4 DOCK FENDERS

- Guard against damaging impact
- Made of age, weather and abrasion-resistant synthetic rubber
- Easy to install and the trim appearance makes them well suited for use on trucks and truck docks
- Half oval shape allows radius to widen upon impact creating better deflection
- Easily installed manually or by power tools
- Hardware is concealed when installation is complete

Note: All given dimensions are nominal and may vary an average of 5% in manufacturing process.

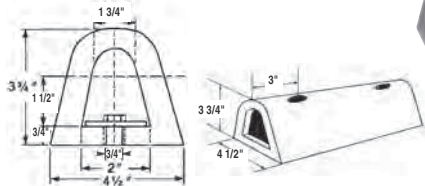

PALLET PULLERS

- Efficient way to unload pallets from trucks
- Hardened teeth give positive grip in any pallet
- One-person operation
- Pulls pallets straight or sideways to get out of tight spots
- Capacity: 5000 lbs.

Optional 20' hook and chain



ML319



KH863

| Model No. | Description | Wt. lbs. |
|-----------|--------------------|----------|
| KH863 | Pallet Puller | 16 |
| ML319 | 20' Hook and Chain | 21 |

AUTO STAND PLUS

- Heavy gauge steel construction
- Gas activated, self-levelling system
- Ergonomic lever action to safely pin, removing the need to bend over
- 16" diameter semi-pneumatic wheels allow for easy outdoor manoeuvring
- Large base pad: 17" x 18 1/2"
- Large trailer contact pad
- Capacity: 100 000 lbs.
- Only one required per trailer
- 1-year warranty**

Model No. ML786



SAF-T-LOK BARS

- Designed for economy and ease of operation
- Constructed with high strength industrial round tubing
- Easy to close and lock with its heavy-duty steel rack, handle and cast aluminum housing
- Replaceable molded pivoting rubber feet, 2" x 4" that grip firmly to trailer walls
- Easy to open trigger release
- Adjusts from 90° to 105°
- Optional cargo hoop set, two hoops, which bolts quickly and easily to provide greater area of holding surfaces (installation hardware included)
- Available in either steel or aluminum versions
- Extra long steel version is available upon request

One piece cargo bar adjusts from 89" to 105" long



| Model No. | Description | Wt. lbs. |
|-----------|-------------------------|----------|
| KH574 | Aluminum Saf-T-Lock Bar | 17 |
| KH575 | Cargo Hoop Set | 15 |

Hoops come complete with installation hardware

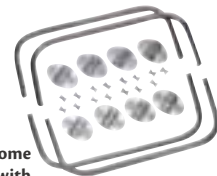

MOUNTING D-4 DOCK FENDERS

On Wood: Use 1/2" lag screws

On Concrete: Use 1/2" self-drilling fasteners

On Steel: Weld 1/2" studs on centers as required



Mounting Bar

In all cases, a drilled metal bar 3/16" x 1 1/2" should be inserted in the bore of the fender to act as a continuous washer.



Diagonal



Horizontal



Vertical

| Fender Drilled Model No. | Mounting Drilled Model No. | Dimensions L" x W" x H" | Anchor Holes | Approx. Wt. lbs. |
|--------------------------|----------------------------|-------------------------|--------------|------------------|
| KH658 | KH662 | 12 x 4 1/2 x 3 3/4 | 2 req., 6"* | 4 |
| KH659 | KH663 | 18 x 4 1/2 x 3 3/4 | 2 req., 12"* | 6 |
| KH660 | KH664 | 24 x 4 1/2 x 3 3/4 | 2 req., 18"* | 9 |
| KH661 | KH665 | 36 x 4 1/2 x 3 3/4 | 3 req., 15"* | 11 |

* Between holes

DOCK EQUIPMENT

ALUMINUM DOCKBOARDS

- For truck or rail applications
- Curb design adds strength and prevents equipment run-off
- Skid resistant safety tread deck
- Bevelled edges for smooth access from either end
- Bend at upper end permits both ends of plate to lie flat
- Steel legs fit between dock and truck or railcar, prevent movement when in use
- High tensile aluminum alloy construction

| Model No. | Cap. lbs. | Inside Curbs" | Overall Width" | Length" | Diff. Height" | Wt. lbs. |
|-----------|-----------|---------------|----------------|---------|---------------|----------|
| KH149 | 4000 | 51 | 54 | 60 | 9 | 164 |
| KH150 | 4000 | 51 | 54 | 72 | 11 | 210 |
| KH151 | 4000 | 57 | 60 | 60 | 9 | 177 |
| KH152 | 4000 | 57 | 60 | 72 | 11 | 225 |
| KH161 | 6000 | 51 | 54 | 48 | 7 | 143 |
| KH162 | 6000 | 50 | 54 | 60 | 9 | 177 |
| KH163 | 6000 | 50 | 54 | 72 | 11 | 225 |
| KH164 | 6000 | 57 | 60 | 48 | 7 | 153 |
| KH165 | 6000 | 56 | 60 | 72 | 11 | 240 |
| KH166 | 6000 | 63 | 66 | 36 | 5 | 123 |
| KH167 | 6000 | 63 | 66 | 48 | 7 | 163 |
| KH168 | 6000 | 62 | 66 | 60 | 9 | 203 |
| KH169 | 6000 | 69 | 72 | 48 | 7 | 174 |
| KH177 | 8000 | 51 | 54 | 36 | 5 | 106 |
| KH178 | 8000 | 50 | 54 | 48 | 7 | 149 |
| KH179 | 8000 | 50 | 54 | 60 | 9 | 188 |
| KH180 | 8000 | 50 | 54 | 72 | 11 | 236 |
| KH181 | 8000 | 57 | 60 | 36 | 5 | 115 |
| KH182 | 8000 | 56 | 60 | 48 | 7 | 160 |
| KH183 | 8000 | 56 | 60 | 60 | 9 | 201 |
| KH184 | 8000 | 56 | 60 | 72 | 11 | 251 |
| KH185 | 8000 | 69 | 72 | 30 | 4 | 110 |
| KH186 | 8000 | 68 | 72 | 48 | 7 | 181 |
| KH187 | 8000 | 68 | 72 | 60 | 9 | 227 |
| KH188 | 8000 | 68 | 72 | 72 | 11 | 282 |
| KH189 | 8000 | 68 | 72 | 84 | 13 | 340 |
| KH105 | 10000 | 51 | 54 | 36 | 5 | 127 |
| KH106 | 10000 | 50 | 54 | 48 | 7 | 176 |
| KH107 | 10000 | 50 | 54 | 60 | 9 | 222 |
| KH108 | 10000 | 50 | 54 | 72 | 11 | 276 |
| KH109 | 10000 | 56 | 60 | 60 | 9 | 239 |
| KH110 | 10000 | 56 | 60 | 72 | 11 | 297 |
| KH111 | 10000 | 63 | 66 | 36 | 5 | 148 |
| KH112 | 10000 | 62 | 66 | 48 | 7 | 197 |
| KH113 | 10000 | 62 | 66 | 60 | 9 | 256 |
| KH115 | 10000 | 69 | 72 | 48 | 7 | 210 |
| KH116 | 10000 | 68 | 72 | 60 | 9 | 273 |
| KH117 | 10000 | 68 | 72 | 72 | 11 | 337 |
| KH118 | 10000 | 68 | 72 | 84 | 13 | 403 |
| KH119 | 12000 | 57 | 60 | 36 | 5 | 137 |
| KH120 | 12000 | 56 | 60 | 48 | 7 | 190 |
| KH121 | 12000 | 56 | 60 | 60 | 9 | 249 |
| KH122 | 12000 | 69 | 72 | 36 | 5 | 158 |
| KH123 | 12000 | 68 | 72 | 48 | 7 | 217 |
| KH125 | 12000 | 68 | 72 | 84 | 13 | 192 |
| KH126 | 14000 | 56 | 60 | 36 | 5 | 143 |
| KH127 | 14000 | 56 | 60 | 48 | 7 | 190 |
| KH128 | 14000 | 56 | 60 | 60 | 9 | 249 |
| KH129 | 14000 | 56 | 60 | 72 | 11 | 313 |
| KH130 | 14000 | 62 | 66 | 36 | 5 | 148 |
| KH131 | 14000 | 62 | 66 | 48 | 7 | 204 |
| KH132 | 14000 | 62 | 66 | 60 | 9 | 266 |
| KH133 | 14000 | 62 | 66 | 72 | 11 | 333 |
| KH134 | 14000 | 68 | 72 | 36 | 5 | 160 |
| KH135 | 14000 | 68 | 72 | 48 | 7 | 220 |
| KH136 | 14000 | 68 | 72 | 60 | 9 | 283 |
| KH137 | 14000 | 68 | 72 | 72 | 11 | 353 |
| KH138 | 14000 | 68 | 72 | 84 | 11 | 456 |
| KH139 | 16000 | 68 | 72 | 60 | 9 | 330 |
| KH140 | 16000 | 68 | 72 | 72 | 11 | 412 |
| KH141 | 16000 | 68 | 72 | 84 | 13 | 540 |
| KH142 | 18000 | 69 | 72 | 36 | 5 | 187 |
| KH143 | 20000 | 68 | 72 | 36 | 5 | 187 |
| KH144 | 20000 | 68 | 72 | 48 | 7 | 267 |
| KH145 | 20000 | 68 | 72 | 60 | 9 | 344 |
| KH146 | 20000 | 68 | 72 | 72 | 11 | 412 |
| KH147 | 20000 | 67 | 72 | 84 | 13 | 564 |

FOB Weston, ON.

All dockboards are made to order (non-returnable)



Bevelled Edges

OPTIONS:

RAIL DOCKBOARDS

- Fixed Spanlocks**
- Provide quick and safe access between dock and railcar, or between railcars
 - Sold in pairs

Model No. KH192

Adjustable Spanlocks

- Permit use of same board on truck or rail docks
- Easily adjusted for various spans
- Sold in pairs

Model No. KH190

FORKLIFT HANDLES

- Makes movement of heavy boards and plates easy and safe
- Recommended for boards and plates over 140 lbs.
- Sold in pairs
- Must be factory installed

Model No. KH191

HOW TO ORDER:

- 1. Determine required capacity:**
90% of gross weight for forklift trucks;
67% of gross weight for powered pallet trucks

Example:

Wt. of Forklift + Wt. of Heaviest Load =
Gross Weight x .90 = Required Capacity
5500 lbs. + 10,000 lbs. = 15 500 x .90 = 13 500 lbs.

- 2. Select dockboard width:** Add 12" to width of equipment to be used on dockboard.

- 3. Determine height differential:** The vertical distance from dock floor to truck floor.

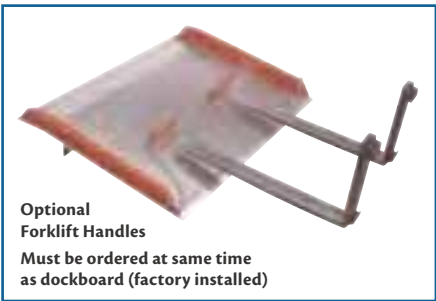

Optional Forklift Handles
Must be ordered at same time as dockboard (factory installed)

DOCKBOARD/RAMP COMBINATION

For a height differential exceeding 11", use a ramp in combination with dockboard. Each board can be converted to an equivalent-size ramp. Call us with your requirements.

ALUMINUM WHEEL RISERS

- Ideal for use when the loading dock is higher than the trailer bed
- Levels out trailer with dock
- Facilitates loading and unloading
- 24" wide
- 25 000 lbs. capacity per pair
- Sold in pairs



| Model No. | Height" | Deck Length" | Approach Length" | Overall Length" | Wt. lbs. per pair |
|-----------|---------|--------------|------------------|-----------------|-------------------|
| KH061 | 6 | 24 | 21 | 45 | 124 |
| KH062 | 8 | 24 | 28 | 52 | 150 |
| KH064 | 10 | 24 | 35 | 59 | 178 |
| KH066 | 12 | 24 | 42 | 66 | 210 |
| KH063 | 6 | 36 | 21 | 57 | 164 |
| KH065 | 8 | 36 | 28 | 64 | 194 |
| KH068 | 10 | 36 | 35 | 71 | 226 |
| KH070 | 12 | 36 | 42 | 78 | 263 |
| KH067 | 6 | 48 | 21 | 69 | 204 |
| KH069 | 8 | 48 | 28 | 76 | 238 |
| KH071 | 10 | 48 | 35 | 83 | 274 |
| KH072 | 12 | 48 | 42 | 90 | 316 |

FOB Weston, ON.

All wheel risers are made to order (non-returnable)

DOCK EQUIPMENT

ALUMINUM DOCKPLATES

Skid resistant safety tread deck. Bevelled edges allow smooth access from either end. Bend at upper end permits both ends of plate to lie flat. Steel legs fit between dock and truck; prevent movement when in use. High tensile aluminum alloy construction; no welds to break.

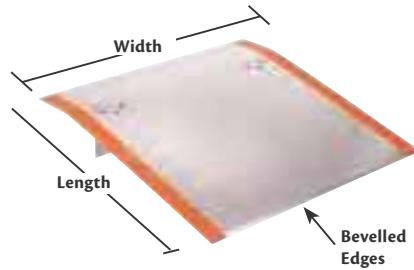

ABOVE DOCK LEVEL

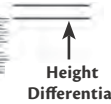

Height Differential



BELOW DOCK LEVEL



Height Differential

HOW TO ORDER:

- 1. SELECT DOCKPLATE WIDTH:**
Add 12" to width of equipment to be used on dockplate.
- 2. DETERMINE HEIGHT DIFFERENTIAL:**
The vertical distance from dock floor to truck floor.
The height differential decides the necessary plate length.
- 3. DETERMINE REQUIRED CAPACITY**

LIGHT-DUTY - 1/4" GA.

REGULAR-DUTY - 3/8" GA.

HEAVY-DUTY - 1/2" GA

EXTRA-HEAVY DUTY - 5/8" GA.

| Model No. | Cap. lbs. | Wt. lbs. | Model No. | Cap. lbs. | Wt. lbs. | Model No. | Cap. lbs. | Wt. lbs. | Model No. | Cap. lbs. | Wt. lbs. | Dimensions W" x L" | Diff. Height" |
|-----------|-----------|----------|-----------|-----------|----------|-----------|-----------|----------|-----------|-----------|----------|--------------------|---------------|
| KH206 | 700 | 53 | KH148 | 1700 | 71 | KH193 | 3000 | 97 | - | - | - | 36 x 48 | 7 |
| KH207 | 800 | 60 | KH153 | 2000 | 82 | KH194 | 3500 | 110 | - | - | - | 42 x 48 | 7 |
| KH208 | 1800 | 36 | KH154 | 4500 | 48 | - | - | - | - | - | - | 48 x 24 | 3 |
| KH209 | 1450 | 44 | KH155 | 3600 | 60 | - | - | - | - | - | - | 48 x 30 | 4 |
| KH210 | 1250 | 52 | KH156 | 3000 | 70 | KH195 | 5400 | 94 | - | - | - | 48 x 36 | 5 |
| KH211 | 1050 | 60 | KH157 | 2600 | 82 | KH196 | 4600 | 110 | - | - | - | 48 x 42 | 6 |
| KH212 | 900 | 67 | KH158 | 2200 | 92 | KH197 | 4000 | 124 | - | - | - | 48 x 48 | 7 |
| KH213 | 760 | 76 | - | - | - | - | - | - | - | - | - | 48 x 54 | 8 |
| KH214 | 600 | 83 | KH159 | 1500 | 114 | KH198 | 2700 | 155 | - | - | - | 48 x 60 | 9 |
| KH215 | 400 | 100 | KH160 | 1100 | 136 | KH199 | 2000 | 184 | - | - | - | 48 x 72 | 11 |
| KH216 | 2200 | 43 | KH170 | 5600 | 59 | KH200 | 10000 | 79 | KH328 | 15600 | 98 | 60 x 24 | 3 |
| KH217 | 1800 | 54 | - | - | - | - | - | - | - | - | - | 60 x 30 | 4 |
| KH218 | 1500 | 63 | KH171 | 3700 | 86 | KH201 | 6700 | 114 | KH329 | 10500 | 141 | 60 x 36 | 5 |
| KH219 | 1300 | 73 | - | - | - | - | - | - | - | - | - | 60 x 42 | 6 |
| KH220 | 1100 | 83 | KH172 | 2800 | 113 | KH202 | 5000 | 151 | KH330 | 7800 | 186 | 60 x 48 | 7 |
| KH221 | 880 | 102 | KH173 | 2200 | 140 | - | - | - | - | - | - | 60 x 60 | 9 |
| KH222 | 2600 | 51 | KH174 | 6700 | 76 | KH203 | 12000 | 94 | KH331 | 18700 | 115 | 72 x 24 | 3 |
| KH223 | 1950 | 63 | - | - | - | - | - | - | - | - | - | 72 x 30 | 4 |
| KH224 | 1650 | 74 | KH175 | 4500 | 105 | KH204 | 8000 | 135 | KH332 | 12600 | 166 | 72 x 36 | 5 |
| KH225 | 1300 | 97 | KH176 | 3300 | 135 | KH205 | 6000 | 178 | KH333 | 9400 | 220 | 72 x 48 | 7 |
| KH226 | 900 | 121 | - | - | - | - | - | - | - | - | - | 72 x 60 | 9 |

FOB Weston, ON.

All dockplates are made to order (non-returnable)

ALUMINUM WALK RAMPS WITH PERFORATED TRACTION GRIP

Ideal for use with hand trucks and platform trucks. Lightweight, portable aluminum walkramps provide a fast, easy means of loading and unloading. Perforated Traction Grip Deck ensures safe, non-slip use in both wet and dry conditions. Determine the length of ramp which will descend at a gradual, safe slope. Safety pins are included to secure walk ramp to truck or dock. **Not for use with pallet trucks or fork lifts.**

APRON MOUNT MODELS

| Model No. | Cap. lbs. | Height Max." 20° Incline | Height Min." 8° | O.A. Width " | Inside Curb Width " | Length' | Wt. lbs. |
|-----------|-----------|--------------------------|-----------------|--------------|---------------------|---------|----------|
| KH320 | 2500 | 22 | 10 | 24 | 21 1/2 | 6 | 55 |
| KH322 | 2500 | 22 | 10 | 26 | 23 1/2 | 6 | 58 |
| KH324 | 2500 | 22 | 10 | 32 | 29 1/2 | 6 | 66 |
| KH326 | 2500 | 22 | 10 | 38 | 35 1/2 | 6 | 75 |
| KH312 | 2000 | 30 | 13 | 24 | 21 1/2 | 8 | 72 |
| KH314 | 2000 | 30 | 13 | 26 | 23 1/2 | 8 | 76 |
| KH316 | 2000 | 30 | 13 | 32 | 29 1/2 | 8 | 88 |
| KH318 | 2000 | 30 | 13 | 38 | 35 1/2 | 8 | 100 |
| KH304 | 1700 | 38 | 16 | 24 | 21 1/2 | 10 | 90 |
| KH306 | 1700 | 38 | 16 | 26 | 23 1/2 | 10 | 95 |
| KH308 | 1700 | 38 | 16 | 32 | 29 1/2 | 10 | 110 |
| KH310 | 1700 | 38 | 16 | 38 | 35 1/2 | 10 | 124 |
| KH296 | 1500 | 46 | 19 | 24 | 21 1/2 | 12 | 108 |
| KH298 | 1500 | 46 | 19 | 26 | 23 1/2 | 12 | 114 |
| KH300 | 1500 | 46 | 19 | 32 | 29 1/2 | 12 | 132 |
| KH302 | 1500 | 46 | 19 | 38 | 35 1/2 | 12 | 149 |
| KH288 | 1300 | 55 | 22 | 24 | 21 1/2 | 14 | 126 |
| KH290 | 1300 | 55 | 22 | 26 | 23 1/2 | 14 | 133 |
| KH292 | 1300 | 55 | 22 | 32 | 29 1/2 | 14 | 153 |
| KH294 | 1300 | 55 | 22 | 38 | 35 1/2 | 14 | 174 |

All prices F.O.B. Weston, Ontario. Hook Mount and Non-Skid treadplate surface also available. All products are made to order and are non-returnable



DOCK LIGHTS

DOCK LIGHTS

- The adjustable models allow flexible horizontal and vertical positioning
- 1 1/2" 14-gauge square steel tubing
- Two-piece wall bracket assures secure mounting
- Available with either metal head or with a "cool to the touch" polycarbonate head that will not dent or break
- Comes with wire lamp guard
- PAR-38 lamp not included
- Certified for sale in Canada by an accredited certification body

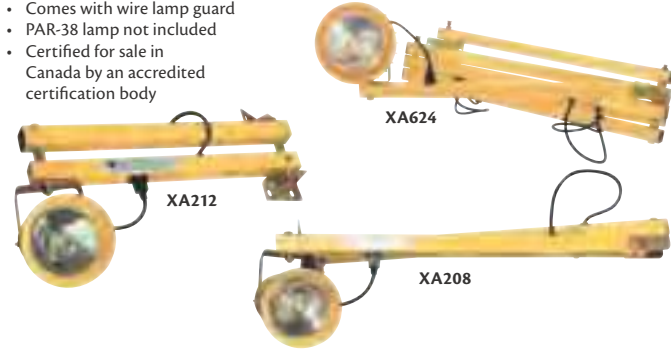

XC224
Replacement
Metal Head



XC445
Replacement
Polycarbonate Head



XA209
Wire Lamp Guard

LED FLEXIBLE ARM DOCK LIGHTS

- Designed to light up the longest of trailers with no wasted light
- LEDs last over 50,000 hours with low heat emission
- Flexible arm allows for unlimited positioning
- Housing is made from durable polycarbonate polymer resistant to cold temperatures
- Low energy usage of 16 W
- Light output equivalent to a 150 W PAR28 bulb
- Dimensions: 42 1/2" L x 6" H
- Weight: 12 lbs.
- Certified for sale in Canada by an accredited certification body

Model No. XC756



HALOGEN DOCK LIGHTS

- 40" full extension
- Tempered glass lens with protective wire guard
- Light fixture can pivot up and down
- Arm has spare bulb holder built in
- Suitable for wet areas
- On/Off toggle switch
- 6' cord with ground
- Includes two 500 W quartz halogen bulbs
- Certified for sale in Canada by an accredited certification body



| Model No. | Description | Wt. lbs. |
|-----------|------------------|----------|
| XA673 | Dock Light | 15 |
| XC464 | Replacement Bulb | - |

| Model No. | Arm Length" | Head Type | Wt. lbs. |
|---|-------------|---------------|----------|
| ADJUSTABLE SINGLE STRUT | | | |
| XA213 | 40 | Metal | 13 |
| XA208 | 60 | Metal | 16 |
| XC446 | 40 | Polycarbonate | 12 |
| XC447 | 60 | Polycarbonate | 15 |
| DOUBLE STRUT - HORIZONTAL POSITIONING ONLY | | | |
| XA212 | 24 | Metal | 13 |
| XA211 | 40 | Metal | 16 |
| XA214 | 60 | Metal | 20 |
| XA349 | 90 | Metal | 29 |
| XC448 | 24 | Polycarbonate | 12 |
| XC449 | 40 | Polycarbonate | 15 |
| XC450 | 60 | Polycarbonate | 19 |
| XC451 | 90 | Polycarbonate | 28 |
| ADJUSTABLE DOUBLE STRUT | | | |
| XA619 | 40 | Metal | 18 |
| XA620 | 60 | Metal | 21 |
| XA621 | 90 | Metal | 31 |
| XA623 | 40 | Polycarbonate | 17 |
| XA624 | 60 | Polycarbonate | 20 |
| XA625 | 90 | Polycarbonate | 30 |

ACCESSORIES

| Model No. | Description |
|-----------|---|
| XA209 | Replacement Wire Guard for Metal Head |
| XC731 | Replacement Wire Guard for Polycarbonate Head |
| XC571 | Replacement PAR-38 Lamp |
| XD043 | Replacement PAR-38 LED Lamp |
| XC224 | Replacement Metal Head |
| XC445 | Replacement Polycarbonate Head |

LED STOP & GO LIGHTS



Uses 80% less energy

- Simple, reliable and cost-effective warning system that reduces the risk of accidents
- Establishes a clear line of communication between drivers and dock personnel
- Safety yellow polypropylene housing will not rust, pit, dent or corrode
- Shallow depth of unit (less than most dock bumpers) prevents damage to the Stop & Go light
- Integral eyebrow-type sun visors create extended visibility
- Mounting holes conform to standard building specifications
- Units can be used indoors or outdoors
- Dimensions: 6 3/8" W x 3 3/4" D x 11 3/8" H
- Lens diameter: 4 1/4"
- Certified for sale in Canada by an accredited certification body



| 12 VDC | Model No. | 24 VDC | 115 VAC | Description | Wt. lbs. |
|--------|-----------|--------|---------|---|----------|
| XC100 | XC101 | XC102 | | Without Flasher or Switch | 2 |
| XC103 | XC104 | XC105 | | With Flasher and Switch | 2 |
| XC106 | XC107 | XC108 | | Set, Including One of Each of the Above | 4 |

HEAVY-DUTY LED DOCK LIGHT

- 40" full extension arm with five pivot points
- Cool to the touch, even if left running for extended lengths of time
- Instant start-up, at full output, even in cold temperatures
- Rugged cast aluminum housing, tempered glass lens
- Low energy usage at 22 W
- LED array lasts for 50,000 hours
- Rated for outdoor use
- 10' power cord with 5-15P plug
- Certified for sale in Canada by an accredited certification body



Model No. XD022



STEEL DRUMS

- Open head 55 US gallon design complies with stringent UN regulations for packing non-dangerous and dangerous goods in packing groups II and III; salvage drum is good for packaging groups I, II and III in solids only
- Closed head 55 US gallon design meets UN regulations for packing of dangerous and non-dangerous goods in the packaging groups II and III and also complies with ISO 15750 standard and other major international standards for steel drums (ANSI, EN)
- Drums feature 2" x 3/4" Tri-Sure® fittings and are available in lined or unlined

UN Regulations:

- A) UN1A1Y1.4140
- B) UN1A1Y2755
- C) UN1A1X1.8300



| Unlined Model No. | UN Compliance | Lined Model No. | UN Compliance | Head Type | Capacity US Gallons | Wt lbs. |
|-------------------|---------------|-----------------|---------------|-----------|---------------------|---------|
| DC145 | A | DC146 | B | Open | 55 | 37 |
| DC147 | C | DC461* | C | Closed | 55 | 35 |

* Unit is painted white

ACCESSORIES

| Model No. | Description |
|-----------|---|
| DC450 | 2" Steel Plug with Buna Gasket |
| DC460 | Lid for Open Head Steel Drum, No Fittings |
| DC455 | Bolt Ring for Open Head Steel Drum |

STEEL SALVAGE DRUMS

- Salvage drums are recommended for containing leaking drums of petroleum solvents
- Includes 12-gauge ring and hoop closure
- Drums are lined with an open head steel top

DC445



| Model No. | Description | Capacity US Gallons | UN Compliance | Steel Gauge | Wt lbs. |
|-----------|-------------|---------------------|---------------|-------------|---------|
| DC445 | Lined | 85 | UN1A2/X440/S | 18 | 77 |
| DC448 | Lined | 85 | UN1A2/X440/S | 16 | 82 |
| DC447 | Lined | 110 | UN1A2/Y409 | 16 | 105 |

LOK-RIM® FIBRE DRUMS

- Provides thermal insulation and protects sensitive products
- Full-open top assures quick filling and dispensing, while the fibre covers and steel chimes reinforce top and bottom
- Unique Lok-Rim® closure allows easy opening and closing and has a tamper evident sealing feature
- Will not corrode and contaminate product
- Compatible with a variety of non hazardous dry and solid products*
- Economical and stackable
- Made of FDA compliant materials



| Model No. | Capacity Gal. | Capacity lbs. | Wt. lbs. |
|-----------|---------------|---------------|----------|
| DC427 | 30 | 225 | 9.4 |
| DC425 | 55 | 300 | 17 |
| DC426 | 55 | 550 | 19 |

* Compatible with semi-liquids when a polyethylene liner/bag is applied

POLYETHYLENE DRUMS

UN-approved plastic drums are manufactured using state-of-the-art technologies to meet the stringent demands of chemical compatibility with hazardous and non-hazardous products as well as reliability and safety requirements. Drums are made from a high molecular weight, high-density polyethylene resin which makes them extremely strong and rigid, allowing for easy handling and low shipping cost. Plastic drums save warehouse space because they are stackable and can be stored outside without rusting. In addition, total packaging costs are decreased when they are reused.



Drums are manufactured in accordance with one of the following UN regulations:

- A) 1H1/Y1.9/150
- B) 1H2/Y250/S
- C) 1H2/X65.0/S
- D) 1H2/Y45.5/S
- E) 1H2/Y150/S

| Model No. Blue | Model No. Black | Model No. Natural | Head Type | Cap Gallons* | Fittings | UN Compliance | Wt. lbs. |
|----------------|-----------------|-------------------|-----------|--------------|-----------------|---------------|----------|
| DC139 | DC140 | DC141 | Closed | 30 | 2" BTR & 2" NPS | A | 14 |
| DC142 | DC143 | DC144 | Closed | 55 | 2" BTR & 2" NPS | A | 21 |
| DC137 | DC138 | - | Open** | 55 | - | B | 22 |
| SEI488 | - | - | Open** | 10 | - | D | 6 |
| SEI489 | - | - | Open** | 15 1/2 | - | C | 8 |
| SEI490 | - | - | Open** | 30 | - | E | 14 |

ACCESSORIES

| Model No. | Description |
|-----------|---------------------------|
| DC149 | 2" Buttress Coarse Thread |
| DC150 | 2" NPS Fine Thread |

* US gallons

** All open head drums come standard with cover and steel lever-locking ring

LIQUIPAK® FIBRE DRUMS

- Interior is lined with heavy duty polyethylene, making it the perfect solution for non-hazardous liquids
- Full-open top assures quick filling and dispensing, while the plastic covers and steel chimes reinforce top and bottom
- Will not corrode and contaminate product
- Economical and stackable
- Complete with bung and vent poly cover fully assembled with locking ring
- Made of FDA compliant materials



| Model No. | Capacity Gal. | Capacity lbs. | Wt. lbs. |
|-----------|---------------|---------------|----------|
| DC428 | 30 | 400 | 12 |
| DC429 | 55 | 600 | 17.5 |
| DC430* | 55 | 600 | 17.5 |

Includes a solid plastic cover without bung holes

RECTANGULAR POLY TIGHT HEAD CONTAINERS

- Suitable for storing and shipping liquid, granular and semi-solid chemicals, detergents, petroleum products, food products, pharmaceuticals and acids
- Recessed handle and anchoring system ensure safe multiple stacking
- Protruding stabilisers prevent tipping
- Ventcaps are included but leakproof screw caps are extra
- Container capacity of 20 litres
- 11 1/2" L x 9 1/2" D x 9 3/4" H



| Model No. | Mfg. No. | Description | Opening mm |
|-----------|----------|------------------------|------------|
| DC163* | 158 | Yellow Container Only | 63 |
| DA684* | 240 | Natural Container Only | 60 |
| DA685 | 284 | Security Cap | 60 |

* Security cap not included

DRUM LINERS

ACCORDION INSERTS FOR 55-GALLON DRUMS

- Made of FDA-compliant materials
- Accordion pleat design adjusts to varying heights of reconditioned drums
- Formed lip grips chime of drum and stays in place during follower plate pumping



| Model No. | Wall Thickness | Qty /Case |
|-----------|----------------|-----------|
| DC338 | 15 mils | 20 |
| DC340 | 18 mils | 15 |
| DC339* | 15 mils | 20 |

* Anti-static

STRAIGHT-SIDED INSERTS FOR 16, 30 & 55-GALLON OPEN HEAD STEEL DRUMS

- Made of FDA compliant materials
- Smooth wall inserts withstand mixing and pumping applications
- Available in anti-static
- Available in polypropylene for hot-fill applications to 440°F
- DC344 used for hot-fill applications



| Model No. | Wall Thickness | Drum Gal. | Qty /Case |
|-----------|----------------|-----------|-----------|
| DC336 | 15 mil | 30 | 25 |
| DC337 | 15 mil | 55 | 20 |
| DC344 | 15 mil | 55 | 10 |
| DC342* | 18 mil | 55 | 15 |
| DC343 | 24 mil | 55 | 15 |

* Anti-static

INSERTS FOR 5-GALLON STEEL PAILS

- Made of FDA compliant materials
- Straight-sided inserts for steel pails are ideal for small batch mixing
- Choose from pliable LDPE or solvent-resistant HDPE
- Available in anti-static
- Available in polypropylene for hot-fill applications to 300°F



| Model No. | Wall Thickness | Material | Qty /Case |
|-----------|----------------|---------------|-----------|
| DC347 | 15 mil | LDPE | 100 |
| DC348 | 15 mil | HDPE | 100 |
| DC349 | 15 mil | Polypropylene | 100 |
| DC492* | 15 mil | LDPE | 100 |

*Anti-static

PAIL INSERTS & STRAINERS

INSERT

- Seamless 14" tall tapered insert provides custom fit for plastic pail
- Average 15-mil thick
- FDA compliant materials

STRAINER

- Heavy-duty strainer ideal for filtering liquids or holding parts for washing
- Featuring 600-micron mesh, finer mesh strainers are available



| Model No. | Material | Size (Gal) | Qty/Case |
|-----------------|----------|------------|----------|
| INSERTS | | | |
| DC350 | HDPE | 5 | 100 |
| DC351 | LDPE | 5 | 100 |
| STRAINER | | | |
| DC049 | | 5 | 48 |
| DB021 | | 55 | 8 |



ULTRALINER DRUM INSERTS FOR 55-GALLON STEEL & FIBRE DRUMS

- Heavy-duty 18-mil insert with ultra thin lip for easy lid closure
- Can be used with fibre and steel drums



| Model No. | Inside Dia." | Wall Thickness | Qty /Case |
|-----------|--------------|----------------|-----------|
| DC345 | 22.5 | 18 mil LDPE | 15 |
| DC346 | 22.5 | 18 mil LDPE | 15 |
| DC493 | 22.5 | 24 mil LDPE | 15 |

FORMFIT LINERS FOR 55-GALLON DRUMS

- Cylindrical film liners are heat-sealed and made of FDA compliant materials
- Available in 40" height to fold over drum or 53" height to tie off
- Available in mil thickness of 4, 8 or 10
- Available in anti-static for solvent-based applications



| Model No. | Height" | Wall Thickness | Qty /Case |
|-----------|---------|----------------|-----------|
| DC353 | 40 | 4 mil | 100 |
| DC354 | 40 | 8 mil | 50 |
| DC355 | 40 | 10 mil | 50 |
| DC494 | 40 | 6 mil | 100 |
| DC356 | 53 | 4 mil | 100 |
| DC495 | 53 | 6 mil | 100 |
| DC357 | 53 | 8 mil | 50 |
| DC358 | 53 | 10 mil | 50 |
| DC359* | 53 | 8 mil | 50 |

* Anti-static

ELASTICIZED DUST CAPS FOR 5, 30 & 55-GALLON CONTAINERS

- Clear 4-mil LDPE caps with elasticized band for easy installation
- Available in anti-static



| Model No. | Drum Gallons |
|-----------|-----------------------------------|
| DC371 | 5 |
| DC375* | 5 |
| DC372 | 30 |
| DC376* | 30 |
| DC373 | 45 |
| DC377* | 45 |
| DC496 | 64" Elastic Cover for Gaylord Box |

* Anti-static



FUSIBLE LINK SELF-CLOSING DRUM COVERS

Convert open top 45-gallon steel drums into fire-safe receptacles for combustible trash. A replaceable fusible link assembly inside the cover melts at 160°F, automatically slamming the cover shut if a fire occurs in the drum. Steel construction; solvent resistant, red baked-on-enamel finish. Fits drums from 22 1/2" to 22 3/4" in diameter. FM approved. Wt. 16 lbs.

Model No. DA097 Mfg. No 26750



DRUM WRENCHES & ACCESSORIES

BUNG NUT WRENCHES

- Fits almost any metal or plastic, male or female bung nuts or plugs
- 13" overall length
- Offset handle
- Weight: 4 lbs.

Model No. DA638

Annealed ductile iron

Model No. DA637

Non-sparking, manganese bronze alloy



DRUM UPENDERS

- 40" long upender provides the necessary leverage for moving horizontal drums to a standing position
- 2 1/2" wide toe plate prevents denting of drum
- 1 1/2" hook fits over most drum heads
- Weight: 12 lbs.

Model No. DA653



DELUXE PLUG WRENCHES

- Non-sparking brass alloy wrench fits virtually all industrial drums including those with square or hex plugs, male or female bung nuts or plugs and fittings with lugs and crossbars
- Built-in 1 1/4" wrench for tightening faucets into drums; eliminates the need for extra tools
- Weight: 2 lbs.

Model No. PE359



CAN TIPPERS

- Handles 5-gallon round pails
- Safety lever holds container in place
- Dispensing height of 11 1/2"
- Capacity: 75 lbs
- Weight: 10 lbs

Model No. DC472



UNIVERSAL PLUG WRENCHES

- Fits virtually all steel, plastic and fibre drum plugs
- 15 1/2" long for extra leverage and hand clearance
- Weight: 4 lbs.

Model No. DA635

Solid ductile iron

Model No. DA636

Non-sparking, zinc aluminum alloy



PLASTIC PAIL OPENERS

- Ideal for opening plastic buckets and pails
- Unique leverage point ends cover distortion and cutting
- Holds pail down while it lifts lid evenly; lid lifts off in seconds
- Aluminum construction
- 16" long
- Weight: 0.5 lbs.

Model No. DA639



DRUM WRENCHES

- Socket head which fits over 3/4" and 2" steel and plastic hex-head plugs
- Also fits other types of closures

Model No. DA647 Non sparking - 2.5 lbs.

Model No. DA643 Socket head - 2.0 lbs.



DRUM DEHEADERS

- Opens any standard size and gauge drum in minutes
- Contoured to drum radius; fast, one-hand operation
- Leaves edge smooth
- Constructed of fine forged steel with a precision quality steel blade
- Weight: 6 lbs.

Model No. DA312

Drum deheader

Model No. DA299

Replacement blade



PAIL PALS

- Designed to open and close virtually any type of steel or plastic pail
- Cast steel construction for durability
- Yellow zinc-plated finish with molded blue plastic hand grip
- Includes a special cutting tool to open sealed lids on plastic pails

Model No. DC041



DRUM ACCESSORIES

BEFORE ORDERING ANY PUMP, ESTABLISHING COMPATIBILITY WITH THE MSDS OF THE FLUID USED IN APPLICATION IS A MUST! BOND/GROUND CABLES ON PAGE B129 ARE REQUIRED WHEN PUMPING FLAMMABLE OR COMBUSTIBLE LIQUIDS.

MANUAL-CLOSING MOLASSES GATE VALVES

- Excellent for dispensing heavy oils, light grease, varnish, molasses, honey, cream and other non-flammable heavy viscous fluids from drums and containers
- All gates have 45-60° discharge for optimum flow control
- Durable cast iron body, painted black enamel finish
- Machined and lapped brass faceplate for smooth operation and perfect seal
- Can be padlocked in sizes up to and including 2"

| Model No. | NPT Inlet Size" | Wt. lbs. |
|-------------------------------------|-----------------|----------|
| STANDARD GATE WITH 2" HANDLE | | |
| DA059 | 3/4 | 1.5 |
| DA060 | 1 | 2.0 |
| DA061 | 1 1/4 | 2.4 |
| DA062 | 1 1/2 | 2.9 |
| DA063 | 2 | 3.2 |
| DA057 | 3 | 6.8 |
| DA058 | 4 | 15.5 |

| Model No. | NPT Inlet Size" | Wt. lbs. |
|--|-----------------|----------|
| STANDARD GATE WITH 4" HANDLE | | |
| DA055 | 1 1/2 | 4.3 |
| DA056 | 2 | 4.6 |
| DA054 | 3 | 7.7 |
| GATE VALVE WITH LOCK NUT, 2" HANDLE | | |
| DA051 | 3/4 | 1.6 |
| DA052 | 1 1/2 | 3.2 |
| DA053 | 2 | 3.6 |



Note: These faucets are intended for use with non-flammable viscous liquids stored in or dispensed from non-pressurized containers at ambient room temperature.

SELF-CLOSING FAUCETS

- For non-flammable liquids only
- No flame arrestor
- 3/4" pipe thread
- Can be padlocked closed
- Natural zinc die cast finish

Model No. PE365



SELF-CLOSING FAUCETS W/SCREEN

- For use with flammable and non-flammable liquids
- Flame arrestor safety faucet
- Standard 3/4" tapered pipe thread
- Can be padlocked closed
- Natural zinc die cast finish

Model No. PE364



MANUAL-CLOSING POLY FAUCETS

- Ideal for use with non-flammable, often corrosive liquids
- Half turn on/off; stays open until shut-off
- Use 2" size for thick, viscous liquids or larger volume flow of thin liquid



| Model No. | Bung" | Wt. lbs. |
|-----------|-------|----------|
| DA048 | 2 | 0.50 |
| DA049 | 3/4 | 0.08 |

FAUCETS

- Approved for use with oils and non-flammables compatible with stainless steel
- Internal flame arrestor
- Teflon gasket, 3/4" NPT connection
- FM approved



GRADUATED DRUM GAUGES VERTICAL DRUM GAUGES

- Constructed of heavy gauge glass in plated steel body with Buna-N seals
- Excellent for most oils, solvents and chemicals
- Combination gauge and faucet permits uninterrupted draining of drum contents with gauge in place
- Mounts through 3/4" bung hole
- Weight: 3 lbs.



WESCO

| Model No. | Description |
|-----------|-------------------|
| DA064 | Gauge Only |
| DA065* | Gauge with Faucet |

* Zinc die cast faucet FM approved for viscous liquids only; no flame arrestor.

- Graduated in gallons, litres, quarters and eighths full
- Heavy steel and plastic construction with leak proof duronitrile gaskets
- Resistant to oil and many chemicals
- Available for 3/4" or 2" NPT bung opening
- Weight: 1 lbs.



| Model No. | Bung" |
|-----------|-------|
| DA069 | 3/4 |
| DA068 | 2 |

HORIZONTAL BRASS VENTS

- Horizontal vents are for use with drums in the horizontal pouring position
- Automatically relieves pressure at 5 PSI
- Flame arrestor prevents sparks and flame from igniting contents
- Manual vacuum relief by lifting and rotating the valve stem
- Maximum flow of 220 CFM at 20 PSI
- Fits 2" NPS bung in steel or plastic drums

Model No. PE362



SELF CLOSING GATE VALVES

- For use with viscous non-corrosive fluids heavier than SAE30 motor oil
- Heavy-duty brass construction
- Self-closing PTFE blade has fast, positive shut off when handle is released
- 4 1/2" wide handle
- Wide opening permits maximum flow
- Fits 2" bung in steel or plastic drums
- Weight: 7 lbs.

Model No. PE363



DRIP PANS

- Pans are filled with sorbent pillows which keep liquids contained and prevents splashing
- Convenient, versatile, and easy to use around the work environment
- Best suited for placing under drums or machinery, and any other areas where drips occur
- The perfect solution for continuous leaks

ZENITH®
Safety Products

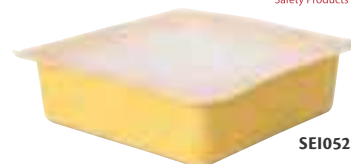

SEI052

| Model No. | Dimensions L" x W" x H" | Absorbency/Pkg. Gal. | Qty /Package |
|-----------------------------|-------------------------|----------------------|--------------|
| DRIP PAN - OIL ONLY | | | |
| SEI052 | 10 1/2 x 10 1/2 x 3 | 1 | 1 |
| DRIP PAN - UNIVERSAL | | | |
| SEI054 | 10 1/2 x 10 1/2 x 3 | 1 | 1 |

DRUM FILL GAUGES

- When drum is almost full, indicator "pops up" to warn you
- Fits in standard 3/4" bung opening
- Length: 5"
- Bright red and yellow molded polyethylene
- Weight: 0.2 oz.
- FM approved

Model No. DA066
Mfg. No. 8530



JUSTRITE®

BEFORE ORDERING ANY PUMP, ESTABLISHING COMPATIBILITY WITH THE MSDS OF THE FLUID USED IN APPLICATION IS A MUST! BOND/GROUND CABLES ON PAGE B129 ARE REQUIRED WHEN PUMPING FLAMMABLE OR COMBUSTIBLE LIQUIDS.

DRUM PUMPS

ROTARY DRUM PUMPS

POLYPROPYLENE

- For most water-soluble inorganic acids, waxes, detergents
- Fits 15 to 55-gallon drums with a 2" bung adaptor
- Transfer rate: 12 oz. per revolution
- **Wetted components:** 304 stainless steel, polypropylene, PVDF, PTFE and Viton®

Model No. DB998



POLYPHENYLENE SULFIDE & STAINLESS STEEL

- Use with most aggressive chemicals such as hydrocarbons and ketones
- Fits 15 to 55-gallon drums with a 2" bung adaptor
- Transfer rate: 12 oz. per revolution
- **Wetted components:** 304 stainless steel, PVDF, polyphenylene sulfide and PTFE

Model No. DC335



#304 STAINLESS STEEL

- For most organic acids, alcohols and solvents
- Fits 15 to 55-gallon drums with a 2" bung adaptor
- Transfer rate: 12 oz. per revolution
- **Wetted components:** 304 stainless steel, PVDF and PTFE

Model No. DB759



PTFE

- For most aggressive chemicals such as acids and alkalines
- Fits 30 to 55-gallon drums with a 2" bung adaptor
- Transfer rate: 12 oz. per revolution
- **Wetted components:** Hastelloy®, PVDF and PTFE

Model No. DC334



STEEL & CAST IRON

- For use with most medium viscosity petroleum fluid, light non-flammable and non-combustible fluids
- Dual directional operation allows pump to both empty and refill containers
- Fits 30 to 55-gallon drums with a 2" bung adaptor
- Transfer rate: 8 oz. per revolution
- **Wetted components:** Buna-N, cast iron, polyethylene, polypropylene and steel
- Steel discharge spout and polyethylene discharge hose of 1" diameter and 55' long included

Model No. DA528

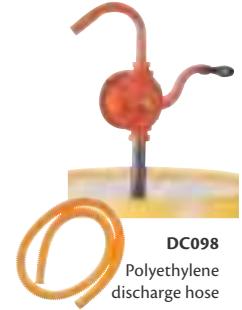

DC098

Polyethylene discharge hose

ALUMINUM

- Use with most medium viscosity petroleum fluid, and non-corrosive fluids
- Fits 15 to 55-gallon drums with a 2" bung adaptor
- Transfer rate: 8 oz. per revolution
- **Wetted components:** Aluminum, Buna-N, polypropylene and steel

Model No. DC112



ALUMINUM

- Use with most low viscosity, non-corrosive petroleum based fluids and lubricating oils up to SAE30
- Fits 15 to 55-gallon drums with a 2" bung adaptor
- Transfer rate: 6.75 oz. per revolution
- Includes a safety locking latch
- **Wetted components:** Aluminum, Buna-N, PVC nitrile, steel and zinc

Model No. DC126



ALUMINUM & CAST IRON

- FM approved pump with 8' antistatic hose, nozzle, flame arrestor and vacuum breaker
- For use with class 1 and class 2 flammable and combustible liquids such as gasoline, alcohols, and other solvents
- Fits 15 to 55-gallon drums with a 2" bung adaptor
- Transfer rate: 10 gallons per minute
- **Wetted components:** Cast iron, steel, graphite, polypropylene, aluminum, EPDM rubber and Buna-N

Model No. DC505



PVC PULL TYPE PUMPS

- For use with most mild acids, detergents, water and solvents
- Good insulation from spark and fire
- Adapts to 3/4" or 2" for 5 to 55-gallon drums
- Transfer rate: 8 oz. per stroke
- **Wetted components:** Polypropylene, polyethylene, PVC and silicone

Model No. DC116



DIAPHRAGM HAND PUMPS

- For petroleum fuels, light lubrication oils, and water-based solutions
- Fits 15 to 55-gallon drums with 2" bung adaptor
- Transfer Rate: 25.5 oz. per stroke
- Includes a safety locking latch
- **Wetted components:** Aluminum, Buna-N, Delrin®, 304 stainless steel and steel

Model No. DC068



NYLON PULL TYPE PUMPS

- For use with most lacquer thinners, mild acids, detergents, water and light viscosity petroleum liquids
- Fits 15 to 55-gallon drums with 2" bung adaptor
- Transfer rate: 14 oz. per stroke
- **Wetted components:** Polypropylene, nylon, 304 stainless steel and PTFE

Model No. DC128



TRANSFER PUMPS

- Non-corrosive, double action piston pump is designed to handle most petroleum products, solvents and industrial chemicals with viscosities up to 2000 SSU
- Discharges approx. 1 quart per stroke with a suction lift to 15'
- Thermoplastic constructed pump has a polyester glass reinforced body, Viton® "O" ring and cork-nitrile gasket
- All internal metal parts in contact with liquid are 316 stainless steel
- **Includes:** 8' PVC black vinyl discharge hose, 2-piece 1" x 34" L polyester suction tube, polyester discharge spout and 2" bung adaptor

Model No. DA526



DRUM PUMPS

BEFORE ORDERING ANY PUMP, ESTABLISHING COMPATIBILITY WITH THE MSDS OF THE FLUID USED IN APPLICATION IS A MUST! BOND/GROUND CABLES ON PAGE B129 ARE REQUIRED WHEN PUMPING FLAMMABLE OR COMBUSTIBLE LIQUIDS.

STAINLESS STEEL PULL TYPE PUMPS

Model No. DA530

- Use with certain acids and alkalis
- Fits 5 to 55-gallon drums with a 2" bung adaptor
- Transfer rate: 8 oz. per stroke
- **Wetted components:** 304 stainless steel, brass, polyethylene and steel



Model No. DA531

- For most acids and corrosives
- Fits 5 to 55-gallon drums with a 2" bung adaptor
- Transfer rate: 8 oz. per stroke
- **Wetted components:** 304 stainless steel, 316 stainless steel, brass and PTFE



Model No. DA529

- For fast transfer of most acids and corrosives
- Fits 55-gallon drums with a 2" bung adaptor
- Transfer rate: 22 oz. per stroke
- **Wetted components:** 304 stainless steel, polyethylene and PTFE



Model No. DB845

- For fast transfer of most acids and corrosives
- Fits 55-gallon drum with a 2" bung adaptor
- Transfer rate: 22 oz. per stroke
- **Wetted components:** 304 stainless steel, 316 stainless steel and PTFE



STEEL PULL TYPE PUMPS

Model No. DA527

- For most non-corrosive and non-flammable liquids
- Fits 5 to 55-gallon drums with a 2" bung adaptor
- Transfer rate: 8 oz. per stroke
- **Wetted components:** Brass, steel and polyethylene



Model No. DC113

- For most water-soluble inorganic acids, waxes, detergents
- Fits 5-gallon pails with a 2" bung adaptor
- Transfer rate: 8 oz. per stroke
- **Wetted components:** Buna-N, polyethylene, leather and steel



Model No. DC114

- Use with most non-corrosive, light to medium viscosity liquids
- Fits 55-gallon drums with a 2" bung adaptor
- 3/4" diameter spout can be rotated to 180° and removed to expose garden hose thread
- Transfer rate: 22 oz. per stroke
- **Wetted components:** Polyethylene, steel and zinc



POLYPROPYLENE PULL TYPE PUMPS

Model No. DC127

- For use with most antifreeze, detergents, windshield fluids, glycerin, and mild acids
- Fits 15 to 55-gallon drums with 2" bung adaptor
- Transfer rate: 14 oz. per stroke
- **Wetted components:** Polypropylene, steel and Viton*



Model No. DC117

- For use with most corrosive chemicals, water, and non-flammable solvents
- Good insulation from spark and fire
- Fits 55-gallon drums with a 2" bung adaptor
- Transfer rate: 22 oz. per stroke
- **Wetted components:** Polyethylene, polypropylene and silicone



Model No. DC115

- For use with most corrosive chemicals and non-flammable solvents
- Fits 5 to 55-gallon drums with 3/4" or 2" bung adaptor
- 360° discharge spout orientation
- Transfer rate: 16 oz. per stroke
- **Wetted components:** Polyethylene, polypropylene, silicone and steel



Model No. DA532

- Use with most corrosive chemicals and non-flammable solvents
- Fits 5 to 55-gallon drums with 3/4" or 2" bung adaptor
- 360° discharge spout orientation
- Transfer rate: 8 oz. per stroke
- **Wetted components:** Polypropylene, polyethylene, silicone and steel



ENVIRO-WEDGE™

The Enviro-Wedge™ increases the amount of product pumped out of 25-45 gallon drums. When the drum is nearly empty tilt it on an angle and position the wedge under the drum. Continue pumping until flow stops. 100% recycled, rugged polyethylene construction. Wt. 1.5 lbs.

Model No. DA660



BEFORE ORDERING ANY PUMP, ESTABLISHING COMPATIBILITY WITH THE MSDS OF THE FLUID USED IN APPLICATION IS A MUST! BOND/GROUND CABLES ON PAGE B129 ARE REQUIRED WHEN PUMPING FLAMMABLE OR COMBUSTIBLE LIQUIDS.

DRUM PUMPS

POLYPROPYLENE LEVER TYPE PUMP

- Use with certain water-based solvents, mild acids and light viscosity petroleum liquids
- Adapts to 1-1/2" or 2" bung adaptor for 5 to 55-gallon drums
- Transfer rate: 14 oz. per stroke

Model No. DC121



POLYPHENYL SULFIDE LEVER TYPE PUMPS

- Use with most water-based solvents, strong acids or alkalis and light viscosity petroleum liquids
- Fits 5 to 55-gallon drums with a 1 1/2" or 2" bung adaptor
- Transfer rate: 14 oz. per stroke

Model No. DC122



PTFE LEVER TYPE PUMPS

- Use with certain water-based solvents, strongest acids or alkaline solutions
- Fits 5 to 55-gallon drums with a 1 1/2" or 2" bung adaptor
- Transfer rate: 14 oz. per stroke

Model No. DC123



STEEL LEVER TYPE PUMP

- Use with most dispensing and transferring non-corrosive and petroleum based fluids
- Cushioned vinyl grip handle
- Discharge spout can be rotated 180° and removed to expose gardenhose threaded outlet
- Adapts to 1-1/2" or 2" bung adaptor for 30 to 55-gallon drums
- Transfer rate: 11 oz. per stroke

Model No. DC124



POLYPROPYLENE LEVER PUMPS

- Delivers approximately 10 ounces per stroke with a capability of 6 gallons per minute
- Manufactured of the highest quality polypropylene
- Will handle viscous materials equivalent to SAE #90 oil; also compatible with most acids, caustics and other mild liquids
- 2" bung adaptor and telescoping extension tube for use with 5 to 45-gallon drums
- 360° discharge spout orientation
- EPDM O-Rings

Model No. DA534



SAFETY PUMPS

- Constructed of highly polished carbon steel with Teflon® piston, packing and gasket for exceptional chemical and solvent resistance
- Steel pickup tube with internal screen keeps debris out of pump
- Pumps 8 oz. per stroke, designed to fit 55-gallon drums
- Comes complete with internal flame arrestor, steel bung adaptor to aid static grounding, and heavy duty bonding wires to remove hazardous static charge
- FM approved for handling flammables
- Also available in stainless steel for corrosive flammable liquids

Model No. DA513 Carbon Steel

Model No. DB831 Stainless Steel



PAIL TYPE PUMPS

- Use with most engine oils, gear oils, and antifreeze
- Fits 5 gallon drums with a 2 1/4" bung adaptor
- Includes a 48" discharge hose fitted with curved metal spout at discharge end
- Transfer rate: 2 oz. per stroke

Model No. DC129



POLYETHYLENE SIPHON PUMPS

- Use with most water based liquids, light oils and detergents
- Air vent in handle controls flow
- Fits 15 to 55-gallon drums with 2" bung adaptor
- Transfer rate: 7 gallons/minute

Model No. DC119



ACID TRANSFER PUMPS

- Designed to transfer most acids
- Body and shaft are constructed of a special polyvinyl chloride with the valves and patented seal of DuPont®'s Viton®
- Intake tube is 38" long and 1 1/2" dia.
- Flow rate is 28 oz. per stroke
- Complete with 3' polyethylene discharge tubing

Warning: Not compatible with most alkalis, acetic acid (30%), hydrofluoric acid and methyl alcohol



Model No. DA810 Adaptor Style Std. 2" IPS Bung



ALKALI TRANSFER PUMPS

- Designed to transfer detergents, waxes, alkalis and certain acids
- Body and shaft are constructed of a special polyvinyl chloride with the valves and seals of DuPont® Hypalon®
- Intake tube is 38" long and 1 1/2" dia.
- Flow rate is 28 oz. per stroke
- Compatible with most alkalis, hydrofluoric acid, acetic acid (30%) and methyl alcohol
- Complete with 3' polyethylene discharge tubing



Model No. DA811 Adaptor Style Std. 2" IPS Bung



PETROLEUM DRUM PUMPS

- Designed to transfer petroleum products
- Body and shaft are constructed of a special polyvinyl chloride with valves of polyurethane, seals of Buna-N and a reinforced vinyl hose
- Intake tube is 38" long and 1 1/2" dia.
- Flow rate is 28 oz. per stroke
- Compatible with petroleum products
- Complete with 3' vinyl discharge tubing



Model No. DA812 Adaptor Style Std. 2" IPS Bung



DRUM HEATERS

NEMA CONFIGURATION



NOTE: DO NOT USE THESE HEATERS IN HAZARDOUS AREAS OR TO HEAT FLAMMABLE MATERIALS. FOR INDOOR USE ONLY.

FLEXIBLE DRUM & PAIL HEATERS

APPLICATIONS

- Preheating • Viscosity control
- Mixing, dipping or pouring
- Temperature control • Freeze protection

FEATURES

- Durable and tough reinforced fibreglass silicone rubber
- Resists moisture, mildew and most chemicals
- Easy to clean and store
- Heavy-duty spring latch assembly, installs or removes in seconds
- 6' power cable w/ NEMA 5-15P plug for the 120 V models
- 6' bare end power cable for the 220 V models



5-GALLON PAIL HEATERS

- Economy 5-gallon heater is suitable for use with plastic and metal pails
- For light duty applications like increasing flow of viscous fluids or heating water
- Aluminised construction
- Adjustable strap clamp allows heater to fit pails with straight or tapered sides from 9 1/2" to 12" in diameter
- 120 V, 100 W
- 6' power cord with standard three pin grounded plug
- Weight: 0.5 lb



Model No. DA074

| Description | Drum Material | Thermostat range | | | | 75°-425°F | |
|----------------------|---------------|------------------|-------|-----------|-------|-----------|-------|
| | | 70°-160°F | | 75°-205°F | | 120 V | 220 V |
| 5 US GALLONS | | | | | | | |
| 6" wide 300 W | Polyethylene | DC295 | DC296 | * | * | * | * |
| 3" wide 300 W | Metal | DC297 | DC298 | DC299 | DC300 | DC301 | DC302 |
| 15 US GALLONS | | | | | | | |
| 6" wide 375 W | Polyethylene | DC303 | DC304 | * | * | * | * |
| 3" wide 500 W | Metal | DC305 | DC306 | DC307 | DC308 | DC309 | DC310 |
| 30 US GALLONS | | | | | | | |
| 6" wide 500 W | Polyethylene | DC311 | DC312 | * | * | * | * |
| 3" wide 750 W | Metal | DC313 | DC314 | DC315 | DC316 | DC317 | DC318 |
| 55 US GALLONS | | | | | | | |
| 6" wide 750 W | Polyethylene | DC319 | DC320 | * | * | * | * |
| 3.25" wide 1000 W | Metal | DC321 | DC322 | DC323 | DC324 | DC325 | DC326 |
| 4.75" wide 1500 W | Metal | DC327 | DC328 | DC329 | DC330 | DC331 | DC332 |

* Polyethylene pails should not be heated beyond 160°F

PLASTIC DRUM HEATERS

- Specifically designed to heat materials contained in polyethylene drums or pails
- Pre-set bimetal thermostat is mounted directly on heating band; activated with on-off switch
- Heat delivered to drum does not exceed 165°F
- 9" wide heating band on 55-gallon model is double the width of standard heaters; increases heater surface area for a shorter heat-up time
- On-off indicator light
- 6' power cord



| Model No. | Drum Cap. Gal. | Drum Dia. " | Plug Type NEMA No. | Volts | Watts | Wt. lbs. |
|-----------|----------------|-------------|--------------------|-------|-------|----------|
| DA080 | 5 | 11 1/4 | 5-15 | 120 | 100 | 7 |
| DA081 | 55 | 22 1/2 | 5-15 | 120 | 800 | 15 |

THERMOSTAT CONTROL HEATERS

- Heats materials with good heat receptivity
- Made of aluminised steel; conjunction box made of galvanised steel
- Increases flow rate of viscous material
- Reaches and maintains a given temperature
- Thermostat bulb senses temperature and controls pre-set heat
- Three-heat switch allows three wattage ratings per thermostat setting
- HIGH setting uses Max. Watts; MEDIUM, 1/2 Max. Watts; LOW, 1/4 Max. Watts
- Neon pilot light
- 6' power cord



| Model No. | Drum Cap. Gal. | Drum Dia. " | Temp Range | Plug Type NEMA no. | Volts | Watts | Wt. lbs. |
|-----------|----------------|-------------|------------|--------------------|-------|-------|----------|
| DA072 | 55 | 22 1/2 | 60-250°F | 5-15 | 120 | 1750 | 15 |
| DA073 | 55 | 22 1/2 | 200-400°F | 5-15 | 120 | 1750 | 15 |
| DA092 | 55 | 22 1/2 | 60-250°F | 5-20 | 120 | 1920 | 15 |
| DA093 | 55 | 22 1/2 | 200-400°F | 5-20 | 120 | 1920 | 15 |
| DA094 | 55 | 22 1/2 | 60-250°F | 6-15 | 240 | 3000 | 15 |
| DA095 | 55 | 22 1/2 | 200-400°F | 6-15 | 240 | 3000 | 15 |
| DA090 | 5 | 11 1/4 | 60-250°F | 5-15 | 120 | 1500 | 5 |
| DA091 | 5 | 11 1/4 | 200-400°F | 5-15 | 120 | 1500 | 5 |
| DA087 | 16 | 14 1/2 | 60-250°F | 5-15 | 120 | 1500 | 8 |
| DA088 | 16 | 14 1/2 | 200-400°F | 5-15 | 120 | 1500 | 8 |

VARIABLE CYCLE CONTROL HEATERS

- Designed to heat materials that have a tendency to burn or cook such as light oils, chemicals, food, and undercoating material
- Variable control cycles heat current on and off
- Ratio of 'time on' to 'time off' increases as setting switch is moved higher
- Cycling allows for a gentle heating of drum contents
- Three heat switch allows three wattage ratings per thermostat setting
- HIGH setting uses Max. Watts; MEDIUM, 1/2 Max. Watts; LOW, 1/4 Max. Watts
- Neon pilot light
- 6' power cord



| Model No. | Drum Cap. Gal. | Drum Dia. " | Plug Type NEMA no. | Volts | Watts | Wt. lbs. |
|-----------|----------------|-------------|--------------------|-------|-------|----------|
| DA084 | 5 | 11 1/4 | 5-15 | 120 | 1500 | 5 |
| DA082 | 16 | 14 1/2 | 5-15 | 120 | 1500 | 8 |
| DA085 | 55 | 22 1/2 | 5-20 | 120 | 1750 | 15 |
| DA086 | 55 | 22 1/2 | 6-15 | 240 | 3000 | 15 |

WATER BOIL-OFF HEATERS

- For use with 55-gallon steel drums only
- Features a 70-300°F thermostat range and a high limit cut off-switch that can be reset
- When water is reduced below the level of the heater the unit shuts off
- Plug type is NEMA no. 6-15
- 240 V, 3000 W, 6' power cord
- Weight: 14 lbs.

Model No. DA096



VALUE HEATERS

- Sturdy aluminised steel construction outlasts and outperforms all silicone rubber heaters
- 0-550°F adjustable thermostat offers wide flexibility when heating contents of 55 gallon, 22 1/2" diameter steel drums
- Heavy-duty, 6' grounded cordset plugs into standard 120 V outlets, 1250 W
- Weight: 8 lbs.

Model No. DA070



BONDING & GROUNDING WIRES

BONDING AND GROUNDING WIRE ASSEMBLIES DISSIPATE THE STATIC ELECTRICITY GENERATED DURING THE TRANSFER OF FLAMMABLE LIQUIDS.

HEAVY-DUTY ASSEMBLIES



TWO HAND CLAMP CONNECTORS

| Model No. | Wire Length" | Wire Description |
|-----------|--------------|------------------|
| DA735 | 36 | Stainless Steel |
| DA736 | 72 | Stainless Steel |
| DA737 | 120 | Stainless Steel |



HAND CLAMPS & 1/4" TERMINAL CONNECTORS

| Model No. | Wire Length" | Wire Description |
|-----------|--------------|------------------|
| DA738 | 36 | Stainless Steel |
| DA739 | 72 | Stainless Steel |
| DA740 | 120 | Stainless Steel |



LIGHT-DUTY ASSEMBLIES

ALLIGATOR CLIPS & 1" BEAM CLAMPS

| Model No. | Wire Length" | Wire Description |
|-----------|--------------|------------------|
| DA621 | 36 | Stainless Steel |
| DA750 | 72 | Stainless Steel |
| DA751 | 120 | Stainless Steel |
| DA623 | 36 | PVC Coated |
| DA752 | 72 | PVC Coated |
| DA753 | 120 | PVC Coated |



TWO ALLIGATOR CLIPS

| Model No. | Wire Length" | Wire Description |
|-----------|--------------|------------------|
| DA622 | 36 | Stainless Steel |
| DA754 | 72 | Stainless Steel |
| DA755 | 120 | Stainless Steel |
| DA756 | 36 | PVC Coated |
| DA757 | 72 | PVC Coated |
| DA758 | 120 | PVC Coated |



ALLIGATOR CLIPS & 1/4" TERMINAL CONNECTORS

| Model No. | Wire Length" | Wire Description |
|-----------|--------------|------------------|
| DA759 | 36 | Stainless Steel |
| DA760 | 72 | Stainless Steel |
| DA761 | 120 | Stainless Steel |



VARIOUS CLAMP STYLES AVAILABLE TO WORK WITH DIFFERENT CONTAINERS. REQUIRED BY OSHA FOR FLUIDS WITH A FLASHPOINT BELOW 140°F.

HEAVY-DUTY STATIC GROUNDING HAND WIND REELS

- Ruggedly constructed reels are an economical alternative to automatic retracting reels
- Fewer parts to maintain, allowing for years of trouble free service
- Highly compact storage of a wide range of cable lengths
- 100A solid copper alligator clip can be substituted with our heavier duty REB clamp when using this reel in outdoor areas or with painted, dirty or rusty surfaces
- Cable Type: Yellow Hytrel coated plated steel



| Model No. | Cord Length (feet) | Cable Size | Dimensions | | | Wt. lbs. |
|-----------|--------------------|---------------------------------|-------------------------|--|--|----------|
| | | | W" x D" x H" | | | |
| DC489 | 50 | 3/32" I.D. coated to 5/32" O.D. | 9 1/5 x 5 3/10 x 9 7/10 | | | 9.8 |
| DC490 | 75 | 3/32" I.D. coated to 5/32" O.D. | 9 1/5 x 5 3/10 x 9 7/10 | | | 10.3 |
| DC491 | 100 | 3/32" I.D. coated to 5/32" O.D. | 9 1/5 x 5 3/10 x 9 7/10 | | | 10.8 |

STATIC GROUNDING CLAMPS

- Cast aluminum construction, available with stainless steel points or brass "cup" points
- Large, heavy-duty clamp designed for grounding railcars, tanker trucks, barges and large vats
- Equipped with a quick release harness, which is designed to open the clamp automatically in case the operator forgets to remove the clamp prior to the vehicle's departure
- Isolated points available for connection to static monitoring system
- Clamp opens to 1 1/4"

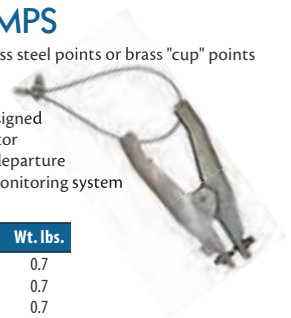

| Model No. | Description | Configuration | Wt. lbs. |
|-----------|------------------------|-----------------------|----------|
| DC484 | Stainless Steel Points | 3 Points | 0.7 |
| DC485 | Stainless Steel Points | 1 Isolated Point | 0.7 |
| DC486 | Brass Cup Points | 1 Isolated Cup Point | 0.7 |
| DC487 | Brass Cup Points | 2 Isolated Cup Points | 0.7 |

RETRACTABLE GROUNDING WIRES

- Replace loose/tangled grounding cables with compact retractable reels
- For use where a discharge of static electricity could cause a spark and subsequent explosion
- Holds 20' to 100' of cable
- Positive latching mechanism holds cable at any length
- A slight pull on the cable releases the mechanism causing retraction
- Bearing surfaces are permanently lubricated
- Alligator clip included
- Heavy-duty reels have robust, weatherproof construction and coated cables
- Functions under extreme environmental conditions
- Available with REB clamp for when attaching clamp to painted, dirty or rusty surfaces



| Model No. | Cable Description | Length' | Wt. lbs. |
|-----------|-----------------------|---------|----------|
| DA609 | Light Duty | 20 | 3.5 |
| DA610 | Light Duty | 50 | 5.5 |
| DB025 | Heavy-Duty Open Style | 50 | 12 |
| DB026 | Heavy-Duty Open Style | 75 | 17 |
| DB027 | Heavy-Duty Open Style | 100 | 22 |



PLIER CLAMPS

COIL CABLES

- Vinyl coated 1/8" cable resists corrosive environments to give years of service
- Unit is self-coiling to retract when not in use
- Includes one heavy-duty pliers-type clamp and one 1/4" terminal end

| Model No. | Coil Length' |
|-----------|--------------|
| DA632 | 5 |
| DA628 | 10 |
| DA777 | 15 |
| DB029 | 20 |
| DA778 | 30 |

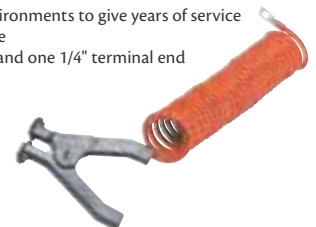

PLIER CLAMPS

- Grounding clamp for flammable drum loading
- Die cast aluminum body, stainless steel points and 55 lbs. spring enable REB clamp to consistently make positive metal to metal ground connection
- Accommodates all cable up to 5/32"; connection is made in clamp's handle held by dual Allen screw contacts



Model No. DA633

DRUM TRUCKS

DRUM HAND TRUCKS

- All welded, 1 1/4" round tubular steel frame
- Handles steel drums from as small as 18" to 25" in diameter
- Ideal for loading drums onto pallets, or for going over curbs or uneven docks
- Free standing when loaded
- Capacity: 1000 lbs.
- Durable Kleton blue enamel finish



DA594

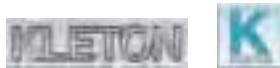

| Model No. | Description | Overall Dim. W" x D" x H" | Wt. lbs. |
|-----------|---------------------------------------|---------------------------|----------|
| DA593 | w/10" Front Rubber Wheels Only | 24 x 19 x 58 | 44 |
| DA594 | w/10" Front and 6" Rear Rubber Wheels | 24 x 22 x 58 | 50 |

DRUM HAND TRUCKS FOR PLASTIC & FIBRE DRUMS

- All welded, 1 1/4" round tubular steel frame
- Handles plastic and fibre drums from 18" to 25" in diameter and 24" to 41" in height
- Rolls on 10" front and 6" rear rubber-tired wheels
- 2" ratchet strap secures drum in place
- Dimensions: 23" W x 24" D x 58" H
- Weight: 56 lbs. • Capacity: 1000 lbs.
- Durable Kleton blue enamel finish



Model No. DA595



ALL-IN-ONE DRUM TRUCKS

- All welded, 1 1/4" round tubular steel frame
- Drum trucks can be used to transport and dispense drums
- Easy-to-use belt-system and hook keeps drums securely on the truck
- Easy to load and unload on skids
- Handles plastic, steel or fibre drums
- Loop handle models provide added leverage while dual handle models provide side body comfort
- Four wheel design for added support and easy manoeuvrability
- Capacity: 1200 lbs.
- Durable Kleton blue enamel finish



Retaining hook



DC266



| Model No. | Handle Type | Wheel Type | Wt. lbs. |
|-----------|-------------|--------------------|----------|
| DC266 | Loop | 10" Mold-On Rubber | 64 |
| DC267 | Loop | 10" Pneumatic | 58 |
| DC256 | Dual | 10" Mold-On Rubber | 62 |
| DC257 | Dual | 10" Pneumatic | 56 |



DC256

ALUMINUM FRAME DRUM TRUCKS

- Static free for use around volatile materials
- Ideal when the truck itself must be lifted or transported
- Rear wheels act as a pivot to raise truck onto curbs or pallets
- Automatic, spring-loaded chime hook engages rim of 25 or 45 imp. gal./55 US gallon steel drums quickly and safely
- 10" x 2 1/2" solid rubber tires
- Hand brake on DA586 is designed to slow down or stop both load carrying wheels whenever necessary
- Gives operator complete control of truck, even on ramps or inclines
- Capacity: 1000 lbs.



| Model No. | Description | Wt. lbs. |
|-----------|-----------------|----------|
| DA582 | Without Brake | 48 |
| DA586 | With Hand Brake | 52 |



DA586

ERGONOMIC DRUM TRUCKS

- Floating axle reduces effort required to break over and balance load
- Chime hook can be stored at the top of the frame for easy use
- Replaceable hard faced double beveled nose prongs
- Handles steel drums only
- 10" mold-on rubber wheels
- Overall dimensions: 17 1/2" L x 23 3/4" W x 61" H
- Capacity: 1000 lbs.
- Weight: 74 lbs.

Model No. DC417



SINGLE BAR DRUM TRUCKS

- Handles 45 imp. gal./55 US gallon steel drums
- Heavy-duty 1" structural pipe frame with double welded joints
- Machined steel load wheels behind nose prongs help ease lifting of drum
- Classic single bar frame design
- Kickstand and vinyl handle grips included
- Available with cast iron centre Mold-On rubber wheels with 1" (ID) roller bearings or polyolefin wheels
- 24" wide at handle, 16 1/4" wide at nose
- Capacity: 1000 lbs.



| Model No. | Wheel Type | Wt. lbs. |
|-----------|----------------|----------|
| DA883 | Polyolefin | 50 |
| DA882 | Mold-On Rubber | 64 |



MULTI-PURPOSE STAINLESS STEEL DRUM TRUCKS

- Handles heavy drums, loads and unloads pallets, and functions as a high capacity drum dispenser
- For use with 70 imperial gallon salvage or overpack drums, 25 and 55 US gallon steel drums and most 25 and 55 US gallon plastic drums
- Extra long U-shaped handle provides added leverage when loading and moving heavy drums
- 63" L x 19 1/2" W frame allows easy access through narrow aisles
- Self-supporting for draining
- Four 8" Mortuf wheels with roller bearings allow truck to travel a straight line and permit easy steering around corners with minimal effort
- All-welded, type 304 stainless steel construction
- Capacity: 1000 lbs.



| Model No. | Wheel Type | Wt. lbs. |
|-----------|------------|----------|
| DA581 | Mortuf | 63 |



DRUM SPOTTERS

- Moves drums to and from pallets easily across floors, effectively and efficiently
- Designed for 45 imp. gal./55 US gallon steel or plastic drums with various rims and most fibre drums with clamp-on lids in a size range of 22" to 23 1/2" diameter and 34 to 36" high, weighing up to 800 lbs.
- Features two forged lifting hooks which slide under the top rim of drum
- Handle provides adequate leverage to lift heavy drums
- Base has built-in counterweight for stability
- Features two 6" polyolefin load wheels and two 4" rear swivel caster for easy steering

Features:

- Simple to operate
- Compact
- Holds drums upright
- No power truck required
- Self-supporting
- No balancing required

| Model No. | Lifting Capacity lbs. | Max. Pallet Height" | Wt. lbs. |
|-----------|-----------------------|---------------------|----------|
| DA933 | 800 | 6 | 145 |



ALL-WELDED DRUM ROCKERS

- Safe method of upending up to 45 imp. gal./55 US gal. drums for moving, draining or storing
- All welded, 1 1/4 round tubular steel frame
- No lifting, straining, or danger of drum tipping backwards
- Removable handle
- Two 3" polyolefin wheels and two swivel casters
- Capacity: 1000 lbs.
- Durable Kleton blue enamel finish



| Model No. | Overall Dimensions W" x D" x H" | Wt. lbs. |
|-----------|------------------------------------|----------|
| DC442 | 33 x 22 x 20 | 38 |

KNOCKED-DOWN DRUM ROCKERS

- Safe method for moving, draining and storing 45 imp. gal./55 US gal. drums
- Two 3" non-sparking wheels and two 3" non-sparking swivel casters
- Removable handle
- Capacity: 700 lbs.
- Powder coat finish
- Shipped knocked down

Model No. DC443

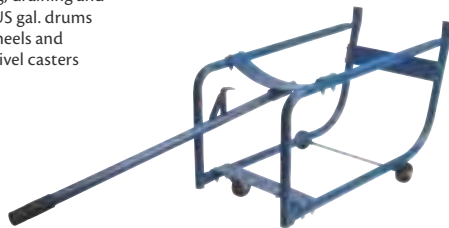

MOBILE DRUM KARRIERS

- Transports, rotates, tilts and drains fully loaded drums up to 800 lbs.
- Drum can be raised to a floor clearance of 5 1/8" to 11 1/2", automatically sets lock
- Tilt lock on each side of unit
- All-welded steel construction; 8" polyolefin wheels and 4" swivel caster
- Weight: 106 lbs.



| Model No. | Drum |
|-----------|--|
| DA189 | 45 imp. gal./55 US gallon Steel; 22 1/2" Dia. |
| DA190 | 45 imp. gal./55 US gallon Plastic and Steel; 22 1/2" - 24" Dia., 34" - 36" H |
| DA191 | 25 and 45 imp. gal./55 US gallon Steel; 18 1/2" - 19" and - 22 1/2" Dia. |
| DA192 | 21" - 23" Dia. Fibre and Steel |
| DA193 | 25 and 45 imp. gal./55 US gallon Fibre and Steel; 18 1/2" - 19" and - 22 1/2" Dia. |

LIL'DOLLY™ PAIL DOLLIES

- Designed for use in hospitals, food processing plants, manufacturing locations, hotels, restaurants and anywhere 5, 6 and 15-gallon pails are used
- Five dual wheel swivel stem casters
- Inside diameter: 11"
- Capacity: 75 lbs.
- Weight: 2 lbs.

Model No. MD527



LOW PROFILE DRUM TRUCKS

- All-welded steel construction with 8" x 2" rubber wheels and a 4" non-marking rubber swivel caster for smooth movement and easy manoeuvrability
- Ideal for moving full, open top 45 imp. gal./55 US gal. drums without spilling contents
- With a low-level frame, only 1/2" from the ground, this truck allows for easy loading of drums
- Hinged handle moves forward and backward for easy pushing or pulling
- Capacity: 1000 lbs.
- Quality powder coat finish
- Shipped knocked down

| Model No. | Overall Dimensions W" x D" x H" | Overall Handle Length" | Wt. lbs. |
|-----------|------------------------------------|------------------------|----------|
| DC500 | 30 x 24 x 46 | 39 | 44 |



STEEL DRUM DOLLIES

- Welded 3/16" thick x 4", frames are built to withstand constant use
- 24" inside diameter handles 45 imp. gal./55 US gal. drums
- Comes with four swivel casters
- Quality powder-coat finish
- Caster assembly required

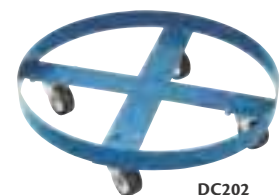

| Model No. | Caster Type | Caster" | Height" | Capacity lbs. | Wt. lbs. |
|--------------------|--------------|---------|---------|---------------|----------|
| ROUND FRAME | | | | | |
| DC202 | Polyolefin | 3 | 4 1/2 | 750 | 21 |
| DC199 | Polyurethane | 3 | 4 1/2 | 1000 | 24 |
| DC200 | Polyurethane | 4 | 5 1/2 | 1500 | 27 |
| DC070* | Frame Only | - | - | - | 16 |
| X-FRAME | | | | | |
| DC206 | Polyolefin | 3 | 4 1/2 | 750 | 13 |
| DC203 | Polyurethane | 3 | 4 1/2 | 1000 | 16 |
| DC204 | Polyurethane | 4 | 5 1/2 | 1500 | 19 |
| DC071* | Frame Only | - | - | - | 8 |

* Fits Caster Hole Spacings of 1 5/8" x 3" to 2 3/4" x 3 1/4"

CLAMP & GO DOLLY HANDLES

- Safely and easily maneuver drum within confined areas
- Perfect for high volume applications
- Low center of gravity provides superior stability
- Quickly clamps onto dollies with various sidewalls of 2", 2 1/2" or 3"
- Foot operated disengage
- Magnet holds handle up to drum for compact storage
- Weight: 11 lbs.

Model No. DC414



LEAK CONTAINMENT DRUM DOLLY

- Polyethylene dolly will not dent, corrode or rust
- Handles 45 imp. gal./55 US gal. drums
- Solid bottom construction with a 2" lip contains spills up to 5 L
- Overall diameter: 24 1/4"
- Capacity: 1000 lbs.
- Grey

| Model No. | Caster Type | Caster" | Height" |
|-----------|--------------|---------|---------|
| DC465 | Polyurethane | 3 | 6 1/4 |
| DC466 | Polyolefin | 3 | 6 1/2 |
| DC467 | Polyolefin | 4 | 7 1/4 |



CUSTOMISE IT TO YOUR SPECIFICATIONS.
See page B71 for details

DRUM LIFTERS

DRUM/OVERPACK LIFTERS

- A safe method of moving 55 US gallon steel drums
- Design allows for quick, gentle loading, drum stays upright during lift
- Low-profile clamp design on 55 US gallon lifter lowers open (lid must be on) or closed head steel drums all the way to bottom of overpack
- 85 gallon overpack lifter picks up both 85 gallon steel overpack drums and 55 US gallon steel drums
- Universal DA876 handles many lever-lock closure fibre drums, typical steel drums and 55 gallon rimmed plastic drums
- Capacity: 1000 lbs.

| Model No. | Description | Wt. lbs. |
|-----------|------------------------------------|----------|
| DA224 | 55 US Gal. Lifter | 21 |
| DA225 | 85 Gal. Overpack/55 US Gal. Lifter | 22 |
| DA876 | Universal Lifter | 25 |
| DC094 | Stainless Steel Universal Lifter | 25 |



AUTOMATIC VERTICAL DRUM LIFTERS

- Lifts and transports closed steel drums easily and effectively
- Unit grips automatically; releases only when drum is set down
- Operator does not have to be at pick up or drop points
- 45-gallon model is available in standard steel or type 304 stainless steel construction
- Capacity: 1000 lbs.

MORSE

| Model No. | Lifts Drum Size Gallons | Construction Material | Wt. lbs. |
|-----------|-------------------------|-----------------------|----------|
| DC091 | 30 | Steel | 45 |
| DA203 | 45 | Steel | 50 |
| DC092 | 45 | Stainless Steel | 50 |
| DC093 | 85 | Steel | 59 |



DRUM LIFTERS

BELOW-HOOK

- Designed for steel, plastic and fibre drums with diameters between 22" to 23 1/2" and heights between 23" to 38"
- Attaches to a monorail, crane or chain block and transports loaded drums in the upright position
- Drum is secured into the saddle by a pawl and ratchet mechanism
- Saddle, as well as the support bar at the bottom of the drum, ensures that drums will be transported safely, restraining the drum from sliding out
- Accepts diameter adaptors for smaller drums



| Model No. | Lifting Capacity lbs. | Wt. lbs. |
|-----------|-----------------------|----------|
| DA935 | 1000 | 61 |

MORSE

POLYESTER DRUM SLING

- Securely and economically lifts steel, plastic and fibre drums from 12" to 24" in diameter
- Ideal for use with a forklift truck
- Compact size of slings allows it to be stored in truck until it's needed
- Reduces drum damage which occurs when using steel handlers
- 2" x 10' endless ratchet strap tightens the reinforced polyester lifting belt around the body of the drum
- 4" x 6' double ply tie down web slips easily over the truck forks
- Capacity: 1000 lbs.
- Wt.: 5 lbs.

Model No. DC470

Note: Open ratchet fully when installing sling



HORIZONTAL DRUM LIFTING HOOKS

- Horizontally lifts 45 imp. gal./55 US gal. steel drums, 34"-36" long
- Alloy steel lifting ring, steel rods, malleable iron hooks
- Capacity: 1000 lbs.
- Weight: 5 lbs.

Model No. DC449

- Spark resistant lifting hook is made of bronze and stainless steel for safe handling
- Capacity: 1000 lbs.
- Weight: 5 lbs.

Model No. DA163



DA163



DC449

MULTI-PURPOSE OVERHEAD DRUM LIFTERS WITH WRENCHES

- Simple three-arm design allows for safe lifting of closed head 30 to 45 imp. gal./55 US gallon steel, plastic, and fibre drums with top lips
- Each removable arm also functions as a wrench for use on different drum plugs, faucets, and rim ring bolts.
- Lifts drums up to 800-lb. capacity
- Powder coat finish for durability
- Weight: 19 lbs.

Model No. DC095

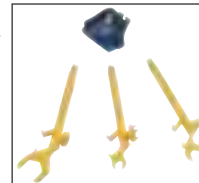

AUTO-GRIP DRUM LIFTERS

- Easy, no-tilt lifting of rimmed steel drums
- Self-energizing: the heavier the load, the tighter the grip
- Attaches to any hoist, crane or forklift using single fork hook attachment
- Heavy-duty, annealed, ductile iron construction
- Large curved foot at bottom of stabilising arm prevents drum damage
- Capacity: 3000 lbs.
- Wt.: 31 lbs.

Model No. DA226



DRUM LIFTERS

- Quick and easy attachment and removal
- Suitable for use with standard steel or poly drums with at least a 3/16" chime
- Lifting arms are adjustable to work with most 55 or 30-gallon drums
- Attaches to any hoist, crane or forklift using single fork hook attachment
- 3-point contact of the lifting arms minimizes deformation
- Also works on closed head drums
- Capacity: 1000 lbs.
- Weight: 15.5 lbs.

Model No. DC420



DRUM LIFTERS & HANDLERS

STEEL SINGLE DRUM GRABBER

- Lift and transport one 45 imp. gal./55 US gallon steel drum without the fork truck driver leaving his seat
- No risk of drum slipping since handler grips under rim of drum or rolling hoops
- Heavy gauge grabber slides onto truck forks and locked with two turn down screws

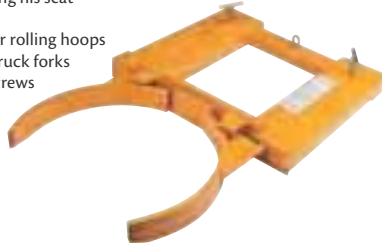

WALTON

| Model No. | Fork Pocket Inner Dia." | | | Capacity lbs./Drum | Wt. lbs. |
|-----------|-------------------------|---|----|--------------------|----------|
| | W" | x | H" | | |
| DC424 | 5 1/2 | x | 2 | 1000 | 121 |

STEEL DOUBLE DRUM GRABBER

- Lift and transport two 45 imp. gal./55 US gallon steel drums without the fork truck driver leaving his seat
- No risk of drum slipping since handler grips under rim of drum or rolling hoops
- Heavy gauge grabber slides onto truck forks and is locked with 2 turn down screws



WESCO

| Model No. | Fork Pocket Inner Dia. | | | Capacity lbs./Drum | Wt. lbs. |
|-----------|------------------------|---|------|--------------------|----------|
| | W" | x | H" | | |
| DC039 | 7 | x | 2.25 | 1000 | 198 |

GATOR GRIP™ FORKLIFT ATTACHMENTS FOR DRUM HANDLING

- Handles steel, plastic and fibre drums
- Patented auto grip lock automatically locks the jaws closed, even over rough terrain
- Adjustable for 30, 50 and 80 US gallon drums
- T-handles fasten safety to any forklift
- Can be used with open or closed head drums
- Capacity: 1000 lbs. per grip

Applications: Shipping, receiving, loading, racking and palletizing



WESCO

| Model No. | Description | Overall Dimensions | | | | Wt. lbs. | |
|-----------|---------------------|--------------------|---|----|---|----------|-----|
| | | W" | x | D" | x | | H" |
| DC268 | Single Drum Handler | 28 | x | 34 | x | 34 | 126 |
| DC269 | Dual Drum Handler | 33 1/4 | x | 34 | x | 34 | 208 |

GRAVITY-ACTUATED MECHANICAL AUTO-GRIP™

- Most efficient on consistently-sized loads
- Equipped with standard jaws only that grip with pressure equal to the weight of the drum and adjusts to fit 30, 55 or 85 gallon steel, fibre or overpack drums
- Adjusts to grasp any cylindrical object 18-28" in diameter
- Spring-and-cam actuated jaws automatically grip while engaging drum
- Jaw dimensions: 3" x 15"
- Fork tube dimensions: 1 5/8" x 5 5/8" x 20"
- Distance between forks is 19 1/2"
- Capacity: 1500 lbs.

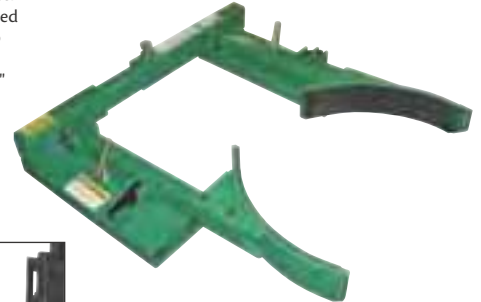

Model No. DA175



VALLEYCRAFT
ALL IN A DAY'S WORK

GRAVITY-ACTUATED MECHANICAL AUTO-GRIP™

- Exclusively designed for use with 45 imp. gal./55 US gallon plastic drums
- 3" jaws fit snugly under top rim of full or empty plastic drums
- Turnbuckle mechanism adjusts to grasp any cylindrical object 22-24" in diameter
- Spring-and-cam actuated jaws automatically grip while pressure of the drum forces them down
- Jaw size: 3" x 15"
- Fork-mounted to easily attach and unattach from forklift in seconds
- Fork tube dimensions: 1 1/8" x 5 5/8" x 20"
- Distance between forks: 19 1/2"
- Capacity: 1000 lbs.

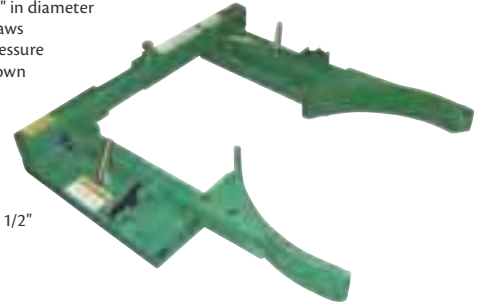

Model No. DC014

VALLEYCRAFT
ALL IN A DAY'S WORK

POLY DRUM LIFTERS



WESCO

- Patented fork truck attachment for handling most 55 and 30 US gallon poly drums
- Fork truck driver does not have to leave cab to engage or disengage drum
- Suited for poly drums that have at least a 3/16" top lip (chime)
- Fork pocket dimensions: inside 1 1/2" x 5 3/8"
- Capacity: 1000 lbs.
- Shipped knocked down

Model No. DA932

DRUM LIFTERS & HANDLERS

GATOR GRIP™ ERGONOMIC DRUM HANDLERS

- Handles steel, plastic and fiber drums
- Patented Auto Grip™ lock automatically locks the jaws closed, even over rough terrain
- Ergonomic solution for lifting, transporting and placing drums on standard pallets or spill pallets
- The jaw clamp is spring loaded and can hold any 3/16" or higher drum rim
- Adjustable for most standard 30, 55 and 85 gallon drums
- Allows a 55 gallon drum to be raised 20" above the floor
- Rolls smoothly on swivel casters which provide easy steering and include a floor lock
- Overall dimensions: 34 1/2" L x 36" W (legs retracted), 37" L x 41" W (legs extended)
- Capacity: 1100 lbs.
- Weight: 356 lbs.

Model No. DC270



FORK MOUNTED DRUM LIFTERS

- Allows operator to raise, transport, tip and drain loaded drums without leaving their seat
- Geared design with pull chain
- Manipulation of pull chain for 360° rotation
- Attaches easily to truck by sliding onto forks and tightening screw locks
- 6 1/2" W x 30" D x 2 1/2" H fork pockets; inside width between truck forks must be at least 24 1/2"
- Options are available to handle plastic, fibre, and steel drums
- 22 1/2" diameter



| Model No. | Drum Gallons | Tilt Type | Full Drum Cap. lbs. | Half Drum Cap. lbs. | Wt. lbs. |
|-----------|---------------|-----------|---------------------|---------------------|----------|
| DA133 | 45 Imp./55 US | Geared | 800 | 500 | 169 |
| DA135 | 45 Imp./55 US | Geared | 1500 | 800 | 178 |
| DA134* | 45 Imp./55 US | Geared | 2000 | 1000 | 361 |

* Can only be used with diameter adaptor DC281

Note: Battery-powered option available

DRUM LIFTERS

Safely transport, position and drain open and closed head steel drums. Simply attach the lifter on hook of chain block, monorail or crane, cinch saddle around drum, and then raise to the required height and position. Ratchet mechanism securely tightens saddle to drum. Choice of manual or geared models.

A. MANUAL TILT

- Ideal for low level pouring and dumping operations
- 800-lb. full drum capacity, 500-lb. half drum capacity
- Tilt lock on each side of hanger frame is used to secure drum in a vertical or horizontal position



| Model No. | Drum Size | Wt. lbs. |
|-----------|--|----------|
| DA199 | 45 Imp. Gal./55 US Gallon Steel; 22 1/2" Dia. | 46 |
| DA200 | 25 and 45 Imp. Gal./55 US Gallon Steel; 18 1/2" - 19" and 22 1/2" Dia. | 46 |
| DA201 | 21" - 23" Dia. Fibre or Steel | 46 |
| DA202 | 25 and 45 Imp. Gal./55 US Gallon Fibre and Steel; 18 1/2" - 19" and 22 1/2" Dia. | 46 |

B. GEARED TILT

- Accurate pouring from any height
- Handles drums up to 2000 lbs. full drum capacity
- Rotation of drum is controlled by 6' chain loop
- Optional MORStop™ tilt brake holds drum tilt position constant even when tension from the pull chain is removed

| Model No. | Drum Size | Full Drum Cap. lbs. | Half Full Cap. lbs. | Wt. lbs. |
|-----------|---|---------------------|---------------------|----------|
| DA121* | 45 Imp. Gal./55 US Gallon Steel; 22" - 23 1/2" Dia. | 800 | 500 | 71 |
| DA124* | 45 Imp. Gal./55 US Gallon Steel; 22 1/2" Dia. | 1500 | 800 | 85 |
| DA123**† | 45 Imp. Gal./55 US Gallon Steel; 22 1/2" Dia. | 2000 | 1000 | 170 |
| DA126 | 25 Gallon Steel; 18 1/2" - 19" Dia. or 45 Imp. Gal./55 US Gallon Steel; 22" - 23 1/2" Dia. | 1500 | 800 | 90 |

OPTION

DC077 MORStop™ Tilt Brake Option

* Chains can be guided into locking slots to hold the drum's position, allowing the operator to let go

** Worm gear speed reducer on DA123 tends to let drum stay where it is stopped

† Can only be used with diameter adaptor DC281

Options and accessories are available for both manual and geared models.



DRUM HANDLERS & RACKS

DRUM STACKING RACKS

- Rack holds two or three 45 imp. gal./55 US gal. drums
- Can be stacked up to three high
- Conveniently stacks drums horizontally increasing space efficiency
- Forklift access from all four sides
- Shipped knocked down



| Model No. | O.A. Dimensions W" x D" x H" | Drum Cap. | Capacity lbs. | Wt. lbs. |
|-----------|---------------------------------|-----------|------------------|-------------|
| DC262 | 45 1/2 x 30 x 12 1/2 | 2 | 1600 | 48 |
| DC263 | 71 1/2 x 30 x 12 1/2 | 3 | 2400 | 75 |

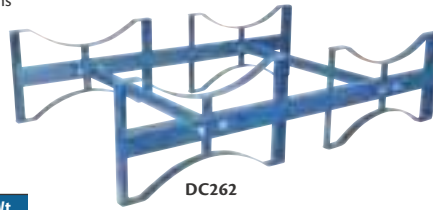

DC262



Drums not included

OPTIONAL DOLLIES

- All welded, ready to use
- Dolly allows stacking racks to be mobile
- Two rigid and two swivel casters
- Durable Kleton blue enamel finish
- Caster assembly required

| Model No. | Wheel Type | Overall Dimensions W" x D" x H" | Capacity lbs. |
|-----------|------------------|------------------------------------|------------------|
| DC392 | 6" Hi-Temp Nylon | 46 x 30 x 9 | 1600 |
| DC393 | 6" Polyurethane | 46 x 30 x 9 | 1600 |



DC392

Use dollies with DC262 and DC263



DC393

REPLACEMENT CASTERS

| Model No. | Description |
|-----------|--------------------------------|
| ML861 | 6" Hi-Temp Nylon Swivel Caster |
| ML862 | 6" Hi-Temp Nylon Rigid Caster |
| ML399 | 6" Polyurethane Swivel Caster |
| ML400 | 6" Polyurethane Rigid Caster |



ML861



ML400

HYDRA-LIFT DRUM HANDLERS

- A safe way to lift, move, tilt and drain 45 imp. gal./55 US gallon drums
- Manual control; pump-handle lifts drum, maximum extension is 45 strokes
- Hand crank controls tilt angle of drum up to 360° in either direction for controlled pouring of contents, chain wheel controls tilt for 72" and higher lift models
- 800-lb. full drum capacity; 500-lb. half-full capacity
- Rugged, heavy-duty welded frame; 8" polyolefin wheels and 4" swivel casters; screw-down floor lock
- Power lift and power tilt with a choice of motors is optional
- Shipped partially disassembled
- Powered models eliminate the manual effort of drum raising and tilting; increases productivity and safety
- Optional MORStop™ tilt brake holds drum tilt position constant even when tension from the pull chain is removed

MANUAL LIFT - For the 60" dispensing height unit, the tilt function is controlled by a hand crank. The 72" and 96" tilt control is with a chain wheel.

POWER LIFT - Moving valve handle to up, down or hold position controls drum height; 15-20 second lifting time.

POWER LIFT & TILT - One valve controls lifting, another controls tilt angle. Ideal when hand crank or chain drop is out of reach.

| Dispensing Height" | H" | L" | O.D." | I.D." |
|--------------------|----|--------|-------|-------|
| 60 | 55 | 60 | 44 | 37 |
| 72 | 55 | 60 | 44 | 37 |
| 96 | 69 | 76 1/2 | 50 | 43 |

| Dispensing Height | | | | Description |
|-------------------|-----------|-----------|--|---|
| 60" | 72" | 96" | | |
| Model No. | Model No. | Model No. | | |
| DA138 | DA143 | DA153 | | Manual Hydra Lift & Tilt |
| DA139† | DA144† | DA154† | | Hydra Lift C/W Air Power Lift & Power Tilt |
| DA141† | DA146† | DA156† | | Hydra Lift C/W Air Power Lift and Manual Tilt |

OPTION

| | |
|-------|----------------------------|
| DC077 | MORStop™ Tilt Brake Option |
|-------|----------------------------|

* Filter, regulator, lubricator and valve not included

† MORStop™ tilt brake option not needed

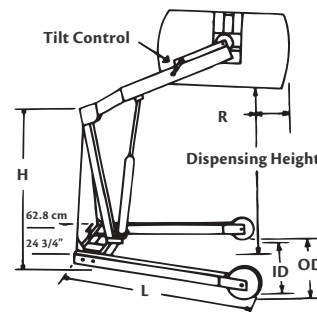
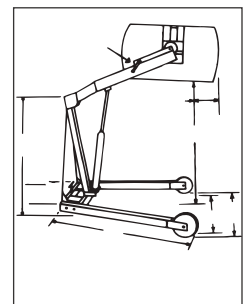

DRUM ACCESSORIES

POLY-DRUM TOPPER™

- Snaps directly onto any 45-gallon open or closed-head drum to keep out debris and protect drum tops
- **Exterior dimensions:**
25 1/2" dia. x 3 3/4" H



| Model No. | Mfg. No. | Description | Wt. lbs. |
|-----------|----------|-------------------|----------|
| SAQ193 | 3065-BK | Poly-Drum Topper™ | 1.5 |

DRUMS-UP™ TRAYS

THE INCIDENTAL SPILL SOLUTION!

- Catch liquid before it reaches the floor, reducing the risk of slip and fall injuries
- Ideal for use as a drum pumping station
- Secondary containment unit features a unique geometric design covering more floor area
- Drain hole makes emptying easy

DRUMS-UP™

- Contains drips for containers up to 55 US gallons
- Control nuisance spills from drums with a 20 US gallon capacity

DRUMS-UP JR™

- Containment for 16 to 30 US gallon drums and 5-gallon pails
- 7 1/2 US gallon capacity



DA104

Drum or pail not included



SD361



| Model No. | Mfg. No. | Description | Dimensions | | Wt. lbs. |
|-----------|----------|---------------|------------|-------|----------|
| | | | Dia. " | H" | |
| DA104 | 8091-YE | Drums-Up™ | 34 | 7 1/4 | 12 |
| SD361 | 8200-YE | Drums-Up Jr.™ | 21 1/2 | 7 1/2 | 4 |

SAFETY DRUM FUNNELS

- Suitable for handling flammables, minimise potentially dangerous spills
- Large 10 3/4" mouth provides quick dumping
- Steel construction with 6" flame arrester for the DA102 and 32" flame arrester for the DA101
- Hinged cover with fusible link reduces spread of vapours
- 2" NPS
- FM approved



| Model No. | Mfg. No. | Flame Arrester" | Wt. lbs. |
|-----------|----------|-----------------|----------|
| DA102 | 8207 | 6 | 11 |
| DA101 | 8205 | 32 | 29 |

UNIVERSAL POLY-DRUM FUNNEL™

- Patented scalloped design, high sidewall and bung fitting holders
- For use with 30 and 55 US gallon drums
- Funnel's nest for compact shipment
- Safety funnel includes a non-sparking safety bung closure with flame arrester for use with flammable liquids
- Optional cover keeps the weather out
- Dimensions: **Exterior** - 26" dia. x 5 1/2" H; **Interior** - 22" dia. x 4" H

SAH566



SAH567/SAH565

| Model No. | Mfg. No. | Description | Wt. lbs. |
|-----------|------------|---------------|----------|
| SAH565 | 3004-4E | Funnel | 3 |
| SAH566 | 3004-YE-SF | Safety Funnel | 5 |
| SAH567 | 3040-YE | Funnel Cover | 3 |



POLY-PAIL FUNNELS™

Mounts to 3 1/2, 5 and 6-gallon tight-head pails. Also fits open top pails with 12" diameter. Optional Poly-Pail Funnel™ cover available.

POLY-PAIL FUNNEL™

- **Exterior Dimensions:** 9 1/4" top dia. x 11" bottom dia. x 2 3/4" H
- **Interior Dimensions:** 8 1/2" x 2 3/8" side wall height

POLY-PAIL FUNNEL™ COVER

- **Exterior Dimensions:** 9 1/4" dia. x 2 3/8" H



| Model No. | Mfg. No. | Description | Wt. lbs. |
|-----------|----------|-------------------------|----------|
| DA098 | 3005-YE | Poly-Pail Funnel™ | 2 |
| SG291 | 3051-YE | Poly-Pail Funnel™ Cover | 3 |

SAFETY FUNNELS WITH VENT

- Provides safe waste solvent disposal due to automatic pressure and vacuum relief
- 9" diameter polyethylene funnel comes with brass safety vent and 6" flame arrester
- Cap comes with safety chain to prevent loss
- 2" NPS/NPT
- FM approved
- Wt.: 4 lbs.

Model No. DA103 Mfg. No. 8211



CHAIN HOISTS

- Lightweight steel construction
- Triple spur geared for easy lifting
- Load brake assures safety and load control
- High tensile alloy steel load chain for increased strength and durability
- Latched swivel hooks for added security
- Enclosed chain guide ensures dirt and dust do not affect operation

| 10' Lift Model No. | 20' Lift Model No. | Capacity Tons | Capacity lbs. | Net Weight lbs. | Net Weight kg | No. of Chain Falls | Load Chain Dia. in. | Load Chain Dia. mm | Headroom in. | Headroom mm |
|--------------------|--------------------|---------------|---------------|-----------------|---------------|--------------------|---------------------|--------------------|--------------|-------------|
| LS534 | LS540 | 1/2 | 1000 | 22 | 10 | 1 | 1/4 | 6 | 10 1/2 | 270 |
| LS535 | LS541 | 1 | 2000 | 26.4 | 12 | 1 | 1/4 | 6 | 12 1/2 | 317 |
| LS536 | LS542 | 1 1/2 | 3000 | 40.7 | 18 1/2 | 1 | 5/16 | 8 | 15 3/4 | 399 |
| LS537 | LS543 | 2 | 4000 | 44 | 20 | 1 | 5/16 | 8 | 16 1/4 | 414 |
| LS538 | LS544 | 3 | 6000 | 63.8 | 29 | 2 | 5/16 | 8 | 18 1/4 | 465 |
| LS539 | LS545 | 5 | 10000 | 100 | 45 1/2 | 2 | 7/16 | 10 | 25 | 636 |

| 10' Lift Model No. | 20' Lift Model No. | A in. | A mm | B in. | B mm | C in. | C mm | D in. | D mm | K in. | K mm |
|--------------------|--------------------|-------|------|-------|------|--------|------|-------|------|-------|------|
| LS534 | LS540 | 5 1/4 | 131 | 5 | 127 | 10 1/2 | 270 | 1 3/8 | 36 | 13/16 | 30 |
| LS535 | LS541 | 5 1/2 | 140 | 6 1/4 | 158 | 12 1/2 | 317 | 1 5/8 | 40 | 1 1/4 | 34 |
| LS536 | LS542 | 6 1/4 | 161 | 7 1/4 | 187 | 15 3/4 | 399 | 1 3/4 | 45 | 1 1/2 | 38 |
| LS537 | LS543 | 6 1/4 | 161 | 7 1/4 | 187 | 16 1/4 | 414 | 2 | 50 | 1 5/8 | 41 |
| LS538 | LS544 | 6 1/4 | 161 | 8 1/4 | 210 | 18 1/4 | 465 | 2 1/4 | 58 | 1 7/8 | 48 |
| LS539 | LS545 | 7 1/4 | 186 | 10 | 253 | 25 | 636 | 2 1/2 | 64 | 2 | 52 |

Note: Dimensions are approximate and should be confirmed if important to your application

LEVER HOISTS

- Lightweight steel construction
- Short steel handle rotates 360° to allow operation in any position
- Load brake assures safety and load control
- High tensile alloy steel load chain for increased strength and durability
- Latched swivel hooks for added security
- Enclosed chain guide ensures dirt and dust do not affect operation

| 5' Lift Model No. | Capacity tons | Capacity lbs. | Net Weight lbs. | Net Weight kg | No. of Chain Falls | Load Chain Dia. in. | Load Chain Dia. mm |
|-------------------|---------------|---------------|-----------------|---------------|--------------------|---------------------|--------------------|
| LS546 | 3/4 | 1500 | 15.5 | 7 | 1 | 1/4 | 6 |
| LS547 | 1 | 2000 | 17.6 | 8 | 1 | 1/4 | 6 |
| LS548 | 1 1/2 | 3000 | 24 | 11 | 1 | 5/16 | 8 |
| LS549 | 3 | 6000 | 46 | 21 | 1 | 7/16 | 10 |
| LS550 | 6 | 12000 | 68 | 31 | 2 | 7/16 | 10 |

| 5' Lift Model No. | A in. | A mm | B in. | B mm | C in. | C mm | D in. | D mm | H in. | H mm | L in. | L mm | K in. | K mm |
|-------------------|-------|------|-------|------|-------|------|-------|------|--------|------|-------|------|--------|------|
| LS546 | 5 3/4 | 148 | 3 1/2 | 90 | 5 1/4 | 136 | 1 1/2 | 40 | 12 3/4 | 325 | 11 | 280 | 1 5/16 | 34 |
| LS547 | 5 3/4 | 148 | 3 1/2 | 90 | 5 1/4 | 136 | 1 1/2 | 40 | 12 3/4 | 325 | 11 | 280 | 1 5/16 | 34 |
| LS548 | 6 3/4 | 172 | 3 3/4 | 98 | 6 1/4 | 160 | 1 3/4 | 45 | 15 | 380 | 16 | 410 | 1 7/16 | 38 |
| LS549 | 7 3/4 | 200 | 4 1/2 | 115 | 7 | 180 | 2 1/4 | 58 | 18 3/4 | 480 | 16 | 410 | 1 7/8 | 48 |
| LS550 | 7 3/4 | 200 | 4 1/2 | 115 | 9 1/4 | 235 | 2 1/2 | 64 | 24 1/2 | 620 | 16 | 410 | 2 1/16 | 52 |

Note: Dimensions are approximate and should be confirmed if important to your application

ADJUSTABLE TROLLEYS

- Easily adjusts to fit various flange and I-beams
- Use on straight or curved track
- Can be installed or removed at any position on the beam
- Heavy-duty cast iron wheels
- Deep width flange provides superior contact with the beam
- Geared trolleys include two geared wheels operated by hand chain
- Safety plate included

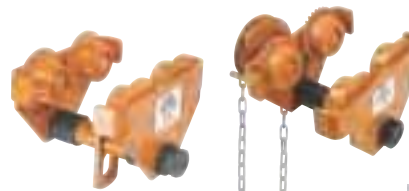

Adjustable Plain Trolley

Adjustable Geared Trolley

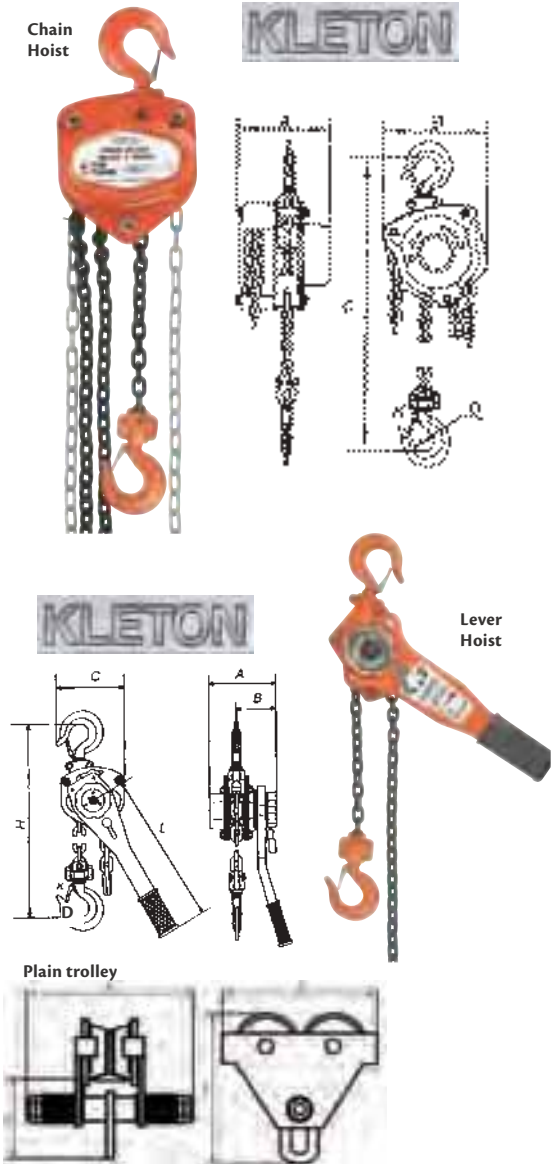

Plain trolley

Geared trolley

| Model No. | Capacity tons | Capacity lbs. | Capacity kg | I-Beam Flange Width in. | I-Beam Flange Width mm | Min. Curve Radius in. | Min. Curve Radius mm | Net Weight lbs. | Net Weight kg | A in. | A mm | B in. | B mm | C in. | C mm | H in. | H mm |
|------------------------|---------------|---------------|-------------|-------------------------|------------------------|-----------------------|----------------------|-----------------|---------------|----------|------|----------|-------|----------|-------|---------|-------|
| PLAIN TROLLEYS | | | | | | | | | | | | | | | | | |
| LS551 | 1/2 | 1000 | 450 | 2 11/16 - 5 3/8 | 68 - 136 | 35 7/16 | 900 | 10 | 4.4 | 8 3/16 | 208 | 8 | 202.4 | 7 3/8 | 187 | 4 59/64 | 125 |
| LS552 | 1 | 2000 | 900 | 3 1/8 - 6 1/4 | 80 - 158 | 39 3/8 | 1000 | 17 | 7.5 | 9 1/2 | 242 | 9 11/64 | 233 | 7 3/4 | 197.7 | 5 | 127.5 |
| LS553 | 2 | 4000 | 1800 | 3 1/8 - 6 1/4 | 80 - 158 | 43 5/16 | 1100 | 28 | 12.5 | 9 27/32 | 250 | 10 11/32 | 262.6 | 9 23/64 | 237.5 | 5 53/64 | 148 |
| LS554 | 3 | 6000 | 2720 | 3 7/16 - 7 3/8 | 88 - 188 | 51 3/16 | 1300 | 46 | 20.6 | 11 13/16 | 300 | 11 3/4 | 298 | 11 7/8 | 301 | 7 23/32 | 196 |
| LS555 | 5 | 10000 | 4530 | 4 13/16 - 9 9/16 | 122 - 243 | 66 15/16 | 1700 | 73 | 33 | 13 1/2 | 343 | 13 3/4 | 349 | 13 3/8 | 340 | 8 37/64 | 218 |
| GEARED TROLLEYS | | | | | | | | | | | | | | | | | |
| LS556 | 1/2 | 1000 | 450 | 2 11/16 - 5 1/4 | 68 - 134 | 35 7/16 | 900 | 18 | 8 | 9 3/4 | 248 | 8 | 202.5 | 7 13/32 | 188 | 4 59/64 | 125 |
| LS557 | 1 | 2000 | 900 | 3 1/8 - 5 15/16 | 80 - 150 | 39 3/8 | 1000 | 25 | 11.5 | 11 | 280 | 9 1/4 | 235 | 7 3/4 | 197 | 4 31/32 | 126 |
| LS558 | 2 | 4000 | 1800 | 3 1/8 - 7 1/16 | 80 - 180 | 43 5/16 | 1100 | 36 | 16.5 | 12 1/2 | 318 | 10 5/32 | 258 | 9 3/8 | 238 | 5 29/32 | 150 |
| LS559 | 3 | 6000 | 2720 | 3 7/16 - 7 3/8 | 88 - 188 | 51 3/16 | 1300 | 54 | 24.5 | 13 3/8 | 340 | 11 1/2 | 293 | 11 3/4 | 298 | 7 31/64 | 190 |
| LS560 | 5 | 10000 | 4530 | 3 15/16 - 6 11/16 | 120 - 196 | 55 1/8 | 1400 | 81 | 36.6 | 14 3/8 | 365 | 13 3/4 | 350 | 13 11/32 | 339 | 8 5/8 | 219 |

Note: Dimensions are approximate and should be confirmed if important to your application

CHAIN & NYLON LIFT SLINGS

CHAIN SLINGS

- Quality grade 80 alloy steel assembled, feature a design factor of 4:1
- Proof tested and certified to twice the working load limit
- Proof test certificate issued with each sling
- Available with sling hook or grab hook
- Three and four leg assemblies are available upon request
- Slings comes with identification tag indicating size, description and working load limit



CAPACITY LBS.

| Chain Size" | CAPACITY LBS. | | | |
|-------------|---------------|--------|------------|--------|
| | Single 90° | 60° | Double 45° | 30° |
| 9/32 | 3,500 | 6,100 | 4,900 | 3,500 |
| 3/8 | 7,100 | 12,300 | 10,000 | 7,100 |
| 1/2 | 12,000 | 20,800 | 17,000 | 12,000 |
| 5/8 | 18,100 | 31,300 | 25,600 | 18,100 |

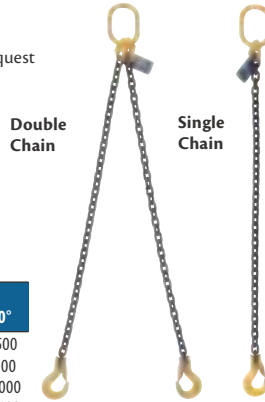

| Chain Size" | Hook Type | 5' Sling Model No. | 8' Sling Model No. | 10' Sling Model No. |
|---------------------|-----------|--------------------|--------------------|---------------------|
| SINGLE CHAIN | | | | |
| 9/32 | Sling | LT521 | LT529 | LT537 |
| 9/32 | Grab | LT522 | LT530 | LT538 |
| 3/8 | Sling | LT523 | LT531 | LT539 |
| 3/8 | Grab | LT524 | LT532 | LT540 |
| 1/2 | Sling | LT525 | LT533 | LT541 |
| 1/2 | Grab | LT526 | LT534 | LT542 |
| 5/8 | Sling | LT527 | LT535 | LT543 |
| 5/8 | Grab | LT528 | LT536 | LT544 |
| DOUBLE CHAIN | | | | |
| 9/32 | Sling | LT545 | LT553 | LT561 |
| 9/32 | Grab | LT546 | LT554 | LT562 |
| 3/8 | Sling | LT547 | LT555 | LT563 |
| 3/8 | Grab | LT548 | LT556 | LT564 |
| 1/2 | Sling | LT549 | LT557 | LT565 |
| 1/2 | Grab | LT550 | LT558 | LT566 |
| 5/8 | Sling | LT551 | LT559 | LT567 |
| 5/8 | Grab | LT552 | LT560 | LT568 |



Sling Hook



Grab hook

Note: Other lengths, hook types and chain types available upon request

NYLON SLINGS

All Uni-Web nylon slings are rated with a 5:1 design factor. Used in conjunction with overhead cranes, hoists or winches. Nylon slings are available in single or double ply to protect heavy, irregular sized loads from scratching or marring. Slings must be checked frequently. Should any surface area show signs of wear or cutting, the sling must be replaced immediately. Each is tagged with manufactured date and capacity.

TYPE 1 CHOKER SLINGS

- Forged alloy end fittings - triangle at one end, choker at the other
- Webbing forms a slip noose by slipping the triangle through the choker

TYPE 2 TRIANGLE SLINGS

- Forged alloy end fittings for single or double sling basket hitches
- Soft webbing conforms to the load shape without damaging painted or polished surfaces

TYPE 3 DOUBLE EYE SLINGS

- Commonly used as a basket and/or choker hitch
- For choker hitch pass one eye through the other flat eye, also makes for easy withdrawal from beneath loads

TYPE 4 TWISTED EYE SLINGS

- Twisted eyes make full functional contact with lifting hooks without the use of hardware
- Widely used for both choker and basket hitches

TYPE 5 ENDLESS SLINGS

- Most versatile and widely used sling
- The economical answer to most lifting problems
- Ideal for vertical, choker, and basket hitches



Type 1

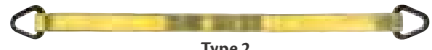

Type 2

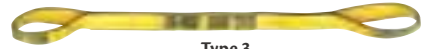

Type 3

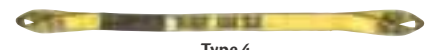

Type 4



Type 5

LOAD LIMIT FOR TYPE 1-2-3-4 CAPACITY LBS.

| Width" | Vertical | | Choker | | Basket | |
|--------|----------|--------|--------|--------|--------|--------|
| | Single | Double | Single | Double | Single | Double |
| 1 | 1600 | 3200 | 1280 | 2560 | 3200 | 6400 |
| 2 | 3200 | 6200 | 2560 | 4960 | 6400 | 12400 |
| 3 | 4700 | 8800 | 3840 | 7000 | 9400 | 17600 |
| 4 | 6200 | 11000 | 4960 | 8800 | 12400 | 22000 |

LOAD LIMIT FOR TYPE 5 CAPACITY LBS.

| Width" | Vertical | | Choker | | Basket | |
|--------|----------|--------|--------|--------|--------|--------|
| | Single | Double | Single | Double | Single | Double |
| 1 | 3200 | 6200 | 2560 | 4960 | 6400 | 12400 |
| 2 | 6200 | 12400 | 4960 | 9930 | 12400 | 24800 |
| 3 | 9400 | 17600 | 7520 | 14080 | 18800 | 35200 |
| 4 | 12400 | 22000 | 9920 | 17600 | 24800 | 44000 |

| | Width" | Ply | 3' | 4' | 6' | 8' | 10' | 12' |
|--------|--------|--------|-----------|-----------|-----------|-----------|-----------|-----------|
| | | | Model No. | Model No. | Model No. | Model No. | Model No. | Model No. |
| TYPE 1 | 2 | Single | LS270 | LS276 | LS282 | LS288 | LS294 | LS300 |
| | | Double | LS271 | LS277 | LS283 | LS289 | LS295 | LS301 |
| | 3 | Single | LS272 | LS278 | LS284 | LS290 | LS296 | LS302 |
| | | Double | LS273 | LS279 | LS285 | LS291 | LS297 | LS303 |
| | 4 | Single | LS274 | LS280 | LS286 | LS292 | LS298 | LS304 |
| | | Double | LS275 | LS281 | LS287 | LS293 | LS299 | LS305 |
| TYPE 2 | 2 | Single | LS306 | LS312 | LS318 | LS324 | LS330 | LS336 |
| | | Double | LS307 | LS313 | LS319 | LS325 | LS331 | LS337 |
| | 3 | Single | LS308 | LS314 | LS320 | LS326 | LS332 | LS338 |
| | | Double | LS309 | LS315 | LS321 | LS327 | LS333 | LS339 |
| | 4 | Single | LS310 | LS316 | LS322 | LS328 | LS334 | LS340 |
| | | Double | LS311 | LS317 | LS323 | LS329 | LS335 | LS341 |
| TYPE 3 | 1 | Single | LS342 | LS350 | LS358 | LS366 | LS374 | LS382 |
| | | Double | LS343 | LS351 | LS359 | LS367 | LS375 | LS383 |
| | 2 | Single | LS344 | LS352 | LS360 | LS368 | LS376 | LS384 |
| | | Double | LS345 | LS353 | LS361 | LS369 | LS377 | LS385 |
| | 3 | Single | LS346 | LS354 | LS362 | LS370 | LS378 | LS386 |
| | | Double | LS347 | LS355 | LS363 | LS371 | LS379 | LS387 |
| | 4 | Single | LS348 | LS356 | LS364 | LS372 | LS380 | LS388 |
| | | Double | LS349 | LS357 | LS365 | LS373 | LS381 | LS389 |

| | Width" | Ply | 3' | 4' | 6' | 8' | 10' | 12' |
|--------|--------|--------|-----------|-----------|-----------|-----------|-----------|-----------|
| | | | Model No. | Model No. | Model No. | Model No. | Model No. | Model No. |
| TYPE 4 | 1 | Single | LS390 | LS398 | LS406 | LS414 | LS422 | LS430 |
| | | Double | LS391 | LS399 | LS407 | LS415 | LS423 | LS431 |
| | 2 | Single | LS392 | LS400 | LS408 | LS416 | LS424 | LS432 |
| | | Double | LS393 | LS401 | LS409 | LS417 | LS425 | LS433 |
| 3 | Single | LS394 | LS402 | LS410 | LS418 | LS426 | LS434 | |
| | Double | LS395 | LS403 | LS411 | LS419 | LS427 | LS435 | |
| 4 | Single | LS396 | LS404 | LS412 | LS420 | LS428 | LS436 | |
| | Double | LS397 | LS405 | LS413 | LS421 | LS429 | LS437 | |
| TYPE 5 | 1 | Single | LS438 | LS446 | LS454 | LS462 | LS470 | LS478 |
| | | Double | LS439 | LS447 | LS455 | LS463 | LS471 | LS479 |
| | 2 | Single | LS440 | LS448 | LS456 | LS464 | LS472 | LS480 |
| | | Double | LS441 | LS449 | LS457 | LS465 | LS473 | LS481 |
| | 3 | Single | LS442 | LS450 | LS458 | LS466 | LS474 | LS482 |
| | | Double | LS443 | LS451 | LS459 | LS467 | LS475 | LS483 |
| | 4 | Single | LS444 | LS452 | LS460 | LS468 | LS476 | LS484 |
| | | Double | LS445 | LS453 | LS461 | LS469 | LS477 | LS485 |

Available in other lengths



VACUUM CUPS & CLAMPS

POLYESTER ROUND SLINGS

- Constructed from multiple high tenacity polyester yarns in an endless/continuous loop
- Excellent resistance to ultra-violet light, rotting and mildew
- The high flexibility allows the sling to conform to the load for a secure hold
- No loss of strength when used in water
- Lightweight, easy to rig, store and clean
- Hook and load contact points can be rotated to extend the service life
- Seamless cover, no edges to wear out
- Maximum temperature exposure: 194°F



| Model No. | Width' | Length' | Colour | Capacity lbs. | | |
|-----------|--------|---------|--------|---------------|--------|------------|
| | | | | Vertical | Choker | 90° Basket |
| LT569 | 2 | 4 | Purple | 3000 | 2400 | 6000 |
| LT570 | 2 | 6 | Purple | 3000 | 2400 | 6000 |
| LT571 | 2 | 8 | Purple | 3000 | 2400 | 6000 |
| LT572 | 2 | 4 | Green | 6000 | 4800 | 12000 |
| LT573 | 2 | 6 | Green | 6000 | 4800 | 12000 |
| LT574 | 2 | 8 | Green | 6000 | 4800 | 12000 |
| LT575 | 2 | 6 | Yellow | 9000 | 7200 | 18000 |
| LT576 | 2 | 8 | Yellow | 9000 | 7200 | 18000 |

| Model No. | Width' | Length' | Colour | Capacity lbs. | | |
|-----------|--------|---------|--------|---------------|--------|------------|
| | | | | Vertical | Choker | 90° Basket |
| LT577 | 2 | 10 | Yellow | 9000 | 7200 | 18000 |
| LT578 | 3 | 6 | Red | 14000 | 11200 | 28000 |
| LT579 | 3 | 8 | Red | 14000 | 11200 | 28000 |
| LT580 | 3 | 10 | Red | 14000 | 11200 | 28000 |
| LT581 | 4 | 8 | Blue | 23000 | 18400 | 46000 |
| LT582 | 4 | 10 | Blue | 23000 | 18400 | 46000 |
| LT583 | 4 | 12 | Blue | 23000 | 18400 | 46000 |

Note: Other lengths available upon request

VACU-LIFTERS

- Powerfully grips and holds material safely
- Vacuum created by cups for easy lifting of heavy weights by either one or two cups
- Ideal for moving heavy gauge metal, marble slabs, plate glass and plastic sheet
- Extended Vacu-Lifters keep operators hands away from dangerous areas
- Especially used in punch press applications
- Made of strengthened steel rods and oil resistant rubber cups
- Positive push-button release valve assures instant release
- 4:1 safety factor

| Model No. | Cup Dia." | Cap. lbs. | Release Type | Handle Length" |
|--|-----------|-----------|--------------|----------------|
| A. HEAVY-DUTY SINGLE CUP | | | | |
| LA881 | 3 | 15 | Trigger-Pull | - |
| LA613 | 4 | 25 | Trigger-Pull | - |
| LA615 | 5 | 35 | Trigger-Pull | - |
| B. HEAVY-DUTY DOUBLE CUP | | | | |
| LA882 | 3 | 30 | Pull-Bar | 7 |
| LA640 | 4 | 50 | Pull-Bar | 10 |
| LA641 | 5 | 75 | Pull-Bar | 10 |
| C. TWO-MAN VACUUM LIFTER - DOUBLE CUP | | | | |
| LA619 | 4 | 50 | Pull-Ring | 31 |
| LA620 | 5 | 75 | Pull-Ring | 31 |

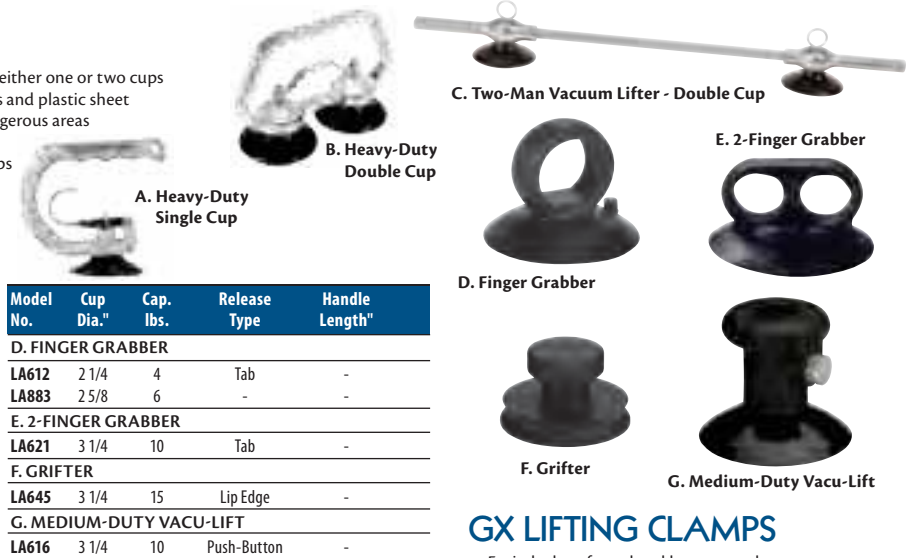

| Model No. | Cup Dia." | Cap. lbs. | Release Type | Handle Length" |
|---------------------------------|-----------|-----------|--------------|----------------|
| D. FINGER GRABBER | | | | |
| LA612 | 2 1/4 | 4 | Tab | - |
| LA883 | 2 5/8 | 6 | - | - |
| E. 2-FINGER GRABBER | | | | |
| LA621 | 3 1/4 | 10 | Tab | - |
| F. GRIFTER | | | | |
| LA645 | 3 1/4 | 15 | Lip Edge | - |
| G. MEDIUM-DUTY VACU-LIFT | | | | |
| LA616 | 3 1/4 | 10 | Push-Button | - |

MANUALLY OPERATED TRIPLE HANDCUPS

- Designed to handle smooth, non-porous loads such as metal, glass, plastic etc. more effectively and more efficiently
- Cast aluminum body with three individual cups
- Ideal for large-sized sheets of material
- 4 3/4" cup diameter
- Capacity: 110 lbs.

Model No. LA863



MANUALLY OPERATED HAND VACUUM CUPS

- Designed to handle smooth, non-porous loads such as metal, glass, plastic etc. more effectively and more efficiently

PUMP ACTION HANDCUPS

- Model No. LA858
- Cast aluminum body with built-in hand pump, 8 1/4" cup diameter
- Includes carrying case (one cup per case)
- Capacity: 123 lbs.



Model No. LT520

- Plastic body with built-in plastic hand pump, 8" cup diameter
- Includes carrying case (one cup per case)
- Capacity: 123 lbs.



DOUBLE HANDCUPS

- Model No. LA859
- Cast aluminum body
- 4 7/8" cup diameter
- Capacity: 66 lbs.

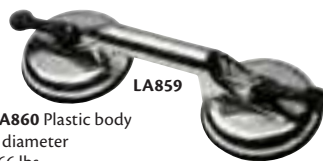

- Model No. LA860 Plastic body
- 4 5/8" cup diameter
- Capacity: 66 lbs.

BEAM CLAMPS

- Beam clamps lift, transfer and position beams from 3" to 10" flange widths using rapid adjustment screw spindle
- Used as portable quick attachments for hoisting and rigging equipment
- 3" diameter eye has cross loading capacity of 15° off centre
- 2:1 safety factor



| Model No. | Cap. Tons* | Jaw Opening" | Wt. lbs. |
|-----------|------------|--------------|----------|
| LA178 | 2 | 3 - 7 1/2 | 13 |
| LA179 | 3 | 3 - 7 1/2 | 15 |
| LA180 | 4 | 6 - 10 | 19 |

* (SWL) Safe Working Loads

GX LIFTING CLAMPS

- Entirely drop forged and heat treated
- Strong, yet lightweight compared to other clamps
- Ideal for both vertical and horizontal-to-vertical lifting
- Features a patented wear out indicator system
- 100% proof tested to twice the working load limit



Campbell®

| Model No | Capacity Tons | Grip Range" | Wt. lbs. |
|----------|---------------|-------------|----------|
| LB606 | 1/2 | 1/16 - 5/8 | 4 |
| LB607 | 1 | 1/16 - 3/4 | 8 |
| LB608 | 3 | 1/16 - 1 | 17 |

GRADE 30 WELDED CHAINS

General purpose chain used for binding, towing, and logging applications.

Important: The chains listed below are not to be used for overhead lifting.

Suitable for ordinary purposes such as log chains, guard rail chains and towing chains. To be used for certain implement and equipment parts where high strength to weight ratios are not a consideration. Coil chain is made with Blu-Krome.



Campbell®

| Model No. | Dim." | Description | Working load Limit lbs. | Feet /Pkg. |
|-----------|-------|------------------|-------------------------|------------|
| LB332 | 3/16 | Proof Coil Chain | 800 | 250 |
| LB333 | 1/4 | Proof Coil Chain | 1300 | 141 |
| LB334 | 5/16 | Proof Coil Chain | 1900 | 92 |
| LB335 | 3/8 | Proof Coil Chain | 2650 | 63 |
| LB336 | 1/2 | Proof Coil Chain | 4500 | 40 |

LIFTING EQUIPMENT

HAND WINCHES

AUTOMATIC BRAKE WINCHES

- Zinc plated
- Self-activating automatic brake system
- Positive holding action of brake system while raising and lowering loads
- Comfort grip handle for positive hold
- Double disc brake on **LA692** and **LA693**
- Load-Lok automatic disc brake system on **LB257** and **LA691**
- Cable pays out after load has been lowered, continued cranking on the winch allows cable remaining on drum to feed out automatically

| Model No. | Type | Cap. lbs. | Gear Ratio | Hub Dia. " | Reel' | Max. Cable Dia. " | Handle Length" | Wt. lbs. |
|-----------|-----------------------|-----------|------------|------------|-------|-------------------|----------------|----------|
| LB257 | Automatic Brake Winch | 600 | 1:1 | 1 1/4 | 85 | 1/8 | 11 | 7.5 |
| LA691 | Automatic Brake Winch | 1000 | 4.1:1 | 2 1/4 | 60 | 7/32 | 11 | 8 |
| LA692 | Automatic Brake Winch | 1500 | 5.1:1 | 2 1/2 | 88 | 1/4 | 11 | 15 |
| LA693 | Automatic Brake Winch | 2500 | 15.8:1 | 3 1/8 | 75 | 5/16 | 11 | 24 |
| LA694 | Worm Gear Winch | 2000 | 4.1:1 | 1 1/2 | 100 | 3/16 | 8 | 11 |
| LA695 | Worm Gear Winch | 3000 | 5.1:1 | 3 1/8 | 90 | 1/4 | 10 | 31 |

WORM GEAR WINCHES

- Self-activated brake mechanism holds load safely in place
- Double mesh worm gear train for quiet operation/optimum wear
- Rear frame reinforcing bar
- Large diameter drum hubs protect steel cable from damage
- High carbon steel on drum gears last longer
- Large handle grip for easy cranking
- **LA695** includes drive ring and 10" handle



ALLOY STEEL HOOKS

- Constructed of grade 100 alloy steel
- Recommended for overhead lifting

Clevis Sling Hooks with Latch

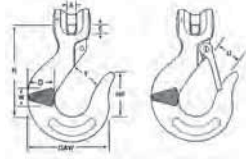

Clevis Grab Hooks

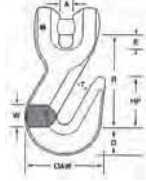

Connecting links



CLEVIS SLING HOOKS WITH LATCH – GRADE 80

| Model No. | Recom. Chain" | Dia. mm | Max. Working Load lbs. | R mm | T mm | U mm | A mm | E mm | D mm | W mm | HP mm | OAW mm | Wt. lbs. |
|-----------|---------------|---------|------------------------|------|------|------|------|------|------|------|-------|--------|----------|
| LB402 | 9/32 | 7 | 4300 | 95 | 32 | 27 | 8 | 9 | 29 | 19 | 44 | 98 | 1.3 |
| LB404 | 1/2 | 13 | 15000 | 146 | 48 | 40 | 14 | 16 | 48 | 32 | 68 | 156 | 5.4 |

CLEVIS GRAB HOOKS – GRADE 80

| Model No. | Recom. Chain" | Dia. mm | Max. Working Load lbs. | R mm | T mm | Load Pin | | | | | | | Wt. lbs. |
|-----------|---------------|---------|------------------------|------|------|----------|------|---------|------|------|-------|--------|----------|
| | | | | | | A mm | E mm | Dia. mm | D mm | W mm | HP mm | OAW mm | |
| LB407 | 9/32 | 7 | 4300 | 60 | 10 | 8 | 9 | 10 | 21 | 16 | 32 | 51 | 0.5 |
| LB408 | 3/8 | 10 | 8800 | 74 | 13 | 11 | 13 | 13 | 32 | 19 | 41 | 71 | 1.6 |
| LB409 | 1/2 | 13 | 15000 | 94 | 17 | 14 | 16 | 16 | 38 | 24 | 51 | 89 | 2.6 |
| LB410 | 5/8 | 16 | 22600 | 113 | 20 | 18 | 19 | 19 | 44 | 31 | 67 | 105 | 5.8 |
| LB411 | 3/4 | 20 | 35300 | 130 | 25 | 21 | 22 | 22 | 54 | 35 | 83 | 124 | 8.8 |

CHAIN TO COMPONENT CONNECTING LINKS

| Model No. | Recom. Chain" | Dia. mm | Max. Working Load lbs. | Load kg | A mm | B mm | C mm | D mm | E mm | F mm | G mm | Wt. lbs. |
|-----------|---------------|---------|------------------------|---------|------|------|------|------|------|------|------|----------|
| LB418 | 7/32 | 5.5 | 2100 | 970 | 7 | 6 | 33 | 11 | 4 | 39 | 10 | 0.1 |
| LB419 | 9/32 | 7 | 4300 | 1950 | 10 | 9 | 40 | 14 | 5 | 56 | 8 | 0.27 |
| LB420 | 3/8 | 10 | 8800 | 4000 | 13 | 11 | 60 | 21 | 8 | 70 | 11 | 0.55 |
| LB421 | 1/2 | 13 | 15000 | 6800 | 17 | 14 | 76 | 26 | 10 | 86 | 16 | 2 |
| LB422 | 5/8 | 16 | 22600 | 10300 | 21 | 18 | 98 | 33 | 12 | 105 | 17 | 3 |
| LB423 | 3/4 | 19 | 35300 | 16000 | 24 | 24 | 117 | 40 | 14 | 121 | 16 | 4 |
| LB424 | 1 | 26 | 47700 | 21600 | 31 | 29 | 149 | 52 | 17 | 149 | 35 | 8 |
| LB425 | 1 1/4 | 32 | 72300 | 32800 | 38 | 35 | 187 | 58 | 24 | 179 | 41 | 16 |

JIB BOOMS

- Converts fork lift trucks into mobile jib cranes for infinite variety of uses
- Fully adjustable booms reach out, pick-up, and move heavy long loads making fork lift more versatile
- Boom slips onto the forks and anchors to the truck with a safety chain
- Includes two adjustable hooks

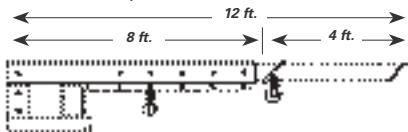

| Model No. | Boom Type | Fork Lift Cap. lbs. | Boom Cap. lbs. (Reach ft.) | | | | | | | Wt. lbs. |
|-----------|-----------|---------------------|----------------------------|------|------|------|------|------|----|----------|
| | | | 0-7 | 8 | 9 | 10 | 11 | 12 | 5" | |
| LA188 | Fixed | 3000 | 1000 | 800 | 725 | 650 | 600 | 500 | 10 | 255 |
| LA187 | Elevating | 3000 | | | | | | | 10 | 285 |
| LA186 | Fixed | 8000 | 3000 | 2700 | 2400 | 2200 | 2000 | 1900 | 12 | 438 |
| LA185 | Elevating | 8000 | | | | | | | 12 | 483 |

F.O.B. Vaudreuil, Quebec. Items are made to order and are non-returnable.

CHAIN HOOKS

- All hooks are grade 40 with a self-coloured finish
- Not to be used for overhead lifting



| Model No. | Dia. " | Max. Working Load Limit lbs. |
|--------------------------------------|--------|------------------------------|
| HEAT TREATED CLEVIS GRAB HOOK | | |
| LT357 | 1/4 | 2600 |
| LT273 | 5/16 | 3900 |
| LT274 | 3/8 | 5400 |
| LT358 | 1/2 | 9200 |
| HEAT TREATED SLIP HOOK | | |
| LT275 | 1/4 | 2600 |
| LT276 | 5/16 | 3900 |
| LT359 | 3/8 | 5400 |
| LT360 | 1/2 | 9200 |

LIFTING HOOKS

Highly secure industrial lifting hooks are manufactured of grade 100 alloy steel, which can be used in all applications. When used in conjunction with grade 80 or 100 alloy chain and fittings, assemblies may be used for overhead lifting.



| Model No. | Dia. " | Max. Working Load Limit lbs. |
|-----------|--------|------------------------------|
| LT277 | 9/32 | 4300 |
| LT278 | 3/8 | 8800 |
| LT279 | 1/2 | 15000 |

F.O.B. Vaudreuil, Quebec. Items are made to order and are non-returnable.

PORTABLE FLOOR CRANES

- Lifts, lowers, positions and moves with ease
- Hand operated hydraulic pump lifts fully extended boom over 8'
- Crane moves easily with smooth rolling casters
- Fully collapsible, knocks down in seconds for easy storage
- 30" adjustable chain and hook supplied
- Shipped knocked down

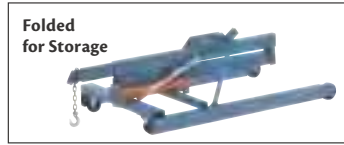

MuscleMate

| Model No. | Cap. lbs. | Overall Height" | Overall Length" | Overall Width" | Caster Type | Wt. lbs. |
|-----------|-----------|-----------------|-----------------|----------------|-------------|----------|
| LA572 | 1000 | 69 1/4 | 63 1/2 | 31 | Phenolic | 260 |
| LA567 | 2000 | 69 1/4 | 63 1/2 | 37 | Cast Iron | 275 |

BOOM CAPACITY

| Model No. | Boom Reach"/Capacity lbs. | | | |
|-----------|---------------------------|--------------------------|--------------------------|--------------------------|
| | 1 st position | 2 nd position | 3 rd position | 4 th position |
| LA572 | 56 1/2/1000 | 63 1/2/770 | 70 1/2/320 | N/A |
| LA567 | 52 1/2/2000 | 62 1/2/1280 | 72 1/2/520 | 82 1/2/380 |

REPLACEMENT PUMP

LA838 Replacement Hydraulic Pump

FLOOR CRANES

REVERSE BOOM

- Counter weight design allows crane to be close to item being lifted without obstruction by the legs
- Reaches over machinery or loading docks easily
- Useful for supplying materials to production areas not serviced by overhead cranes
- Roller bearing wheels, swivel wheel foot brakes, manual pump, adjustable chain and hook, safety pins, push handle and counterweight all included
- LA793 and LA794 fold up for compact storage and transportation

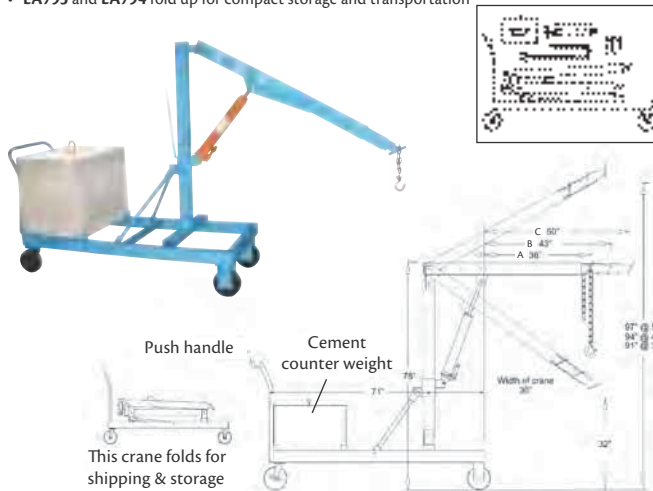

| Model No. | Boom Capacity lbs. | | | Counterweight lbs. | Width" | Wt. lbs. |
|-----------|--------------------|------|------|--------------------|--------|----------|
| | A | B | C | | | |
| LA793* | 1000 | 770 | 650 | 650 | 30 | 1050 |
| LA794* | 2000 | 1280 | 1000 | 1300 | 30 | 1750 |
| LA795 | 3000 | 2000 | 1500 | 1950 | 30 | 2450 |

REPLACEMENT PUMPS

LA838 Replacement Hydraulic Pump for LA793 and LA794

LA840 Replacement Hydraulic Pump for LA795

DIMENSIONS

| Boom Reach | | | Lift Clearance | |
|------------|----|----|----------------|---------------------------|
| A" | B" | C" | Min" | Max" |
| 36 | 43 | 50 | 32 | 91 @ 36, 94 @ 43, 97 @ 50 |

* Shipped knocked down

PORTABLE SHOP CRANES

- Versatile crane provides lifting power to any job site
- Fast and easy assembly/disassembly
- Disassembled unit fits into trunk of car
- Heaviest piece weighs 40 lbs.
- Crane is equipped with heavy-duty cast iron wheels, manual pump, safety hook and push handle
- Shipped knocked down

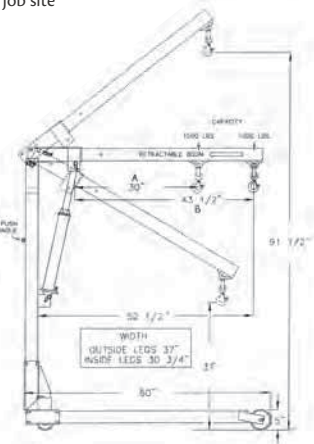
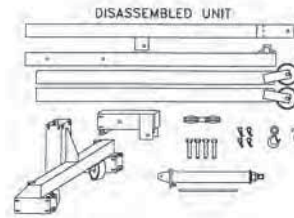

MuscleMate

| Model No. | Boom Reach"/Capacity lbs. | | Lift Clearance | | Width Inside Legs" | Wt. lbs. |
|-----------|---------------------------|-------------|----------------|--------|--------------------|----------|
| | A | B | Min" | Max" | | |
| LA791 | 30/1500 | 43 1/2/1000 | 31 | 91 1/2 | 30 3/4 | 230 |

REPLACEMENT PUMP

LA838 Replacement Hydraulic Pump

ROTATING

- Move load to either side quickly and safely
- Adjustable outrigger provides stability for side loading
- Allows boom to swing 200° to either side while holding a full load
- Useful in tight work spaces
- Outrigger extends to one side at a time
- Equipped with heavy-duty roller bearing wheels, manual pump, adjustable chain and hook, safety pins and guide handle

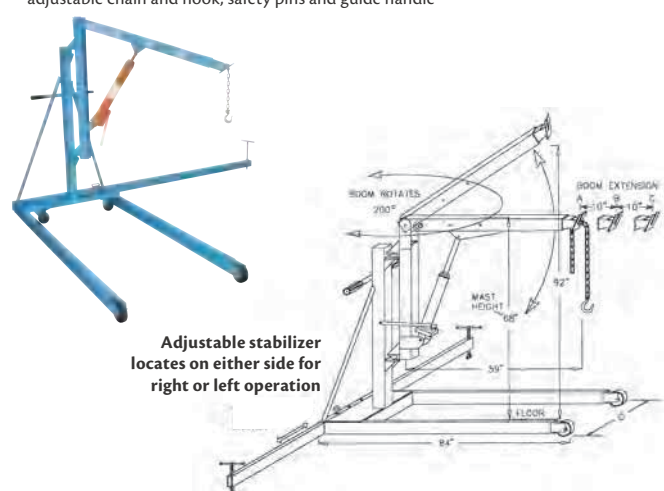

| Model No. | Boom Capacity lbs. | | | Width" D | Wheel Dia." Front Rear | | Wt. lbs. |
|-----------|--------------------|------|------|----------|------------------------|---|----------|
| | A | B | C | | 5 | 4 | |
| LA796 | 1000 | 770 | 650 | 36 | 5 | 4 | 450 |
| LA797 | 2000 | 1280 | 1000 | 36 | 5 | 4 | 550 |
| LA798 | 3000 | 1500 | 1200 | 40 | 8 | 6 | 690 |

REPLACEMENT PUMPS

LA838 Replacement Hydraulic Pump for LA796 and LA797

LA840 Replacement Hydraulic Pump for LA798

DIMENSIONS

| Boom Reach | | | Lift Clearance | |
|------------|----|----|----------------|------|
| A" | B" | C" | Min" | Max" |
| 59 | 69 | 79 | 68 | 92 |

CRANES & PALLET LIFTERS

F.O.B. Vaudreuil, Quebec. Items are made to order and are non-returnable.

ADJUSTABLE GANTRY CRANES

- Adjustable height between 8' and 14'
- Four heavy-duty swivel casters with wheel brakes
- Beam type is I and taper-wheel trolleys are required
- Hoist and trolley not included
- Unit can be adjusted with or without casters
- Shipped knocked down

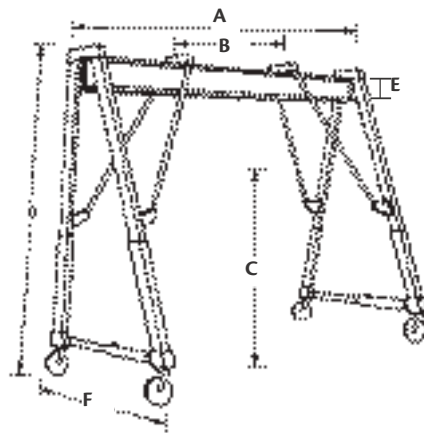

| Model No. | Lifting Cap. lbs. | Overall Span A' | Clear Span B | Hook Lift Min/Max C | Overall Height Min/Max D | Beam Height E" | Wheel Spread Min/Max F | Beam Width" | Wt. lbs. |
|-----------|-------------------|-----------------|--------------|---------------------|--------------------------|----------------|------------------------|-------------|----------|
| LA189 | 2000 | 10 | 4'7" | 6'6 1/2"/12' 4 1/2" | 8'9"/14'7" | 6 | 4'7"/7' | 3 3/8 | 885 |
| LA190 | 2000 | 15 | 9'7" | 6'4 1/2"/12'2 1/2" | 8'9"/14'7" | 8 | 4'7"/7' | 5 1/4 | 1050 |
| LA191 | 4000 | 10 | 4'7" | 6'4 1/2"/12'2 1/2" | 8'9"/14'7" | 8 | 4'7"/7' | 4 | 1165 |
| LA192 | 4000 | 15 | 9'7" | 5'10 1/2"/11'8 1/2" | 8'9"/14'7" | 10 | 4'7"/7' | 5 3/4 | 1370 |
| LA193 | 6000 | 10 | 4'7" | 5'9"/11'7" | 8'9"/14'9" | 10 | 4'10"/7'3" | 4 5/8 | 1430 |
| LA194 | 6000 | 15 | 9'7" | 5'9"/11'7" | 8'9"/14'9" | 10 | 4'10"/7'3" | 5 3/4 | 1615 |

PALLET LIFTERS

- Ideal for use with a crane system or truck cranes
- Pallet lifters available in four capacities with three adjustable or non-adjustable fork lengths to choose from

A - Throat height (clear): 48"
 B - Fork length: 36", 42" or 48"
 C - Width (O.D.): 27"

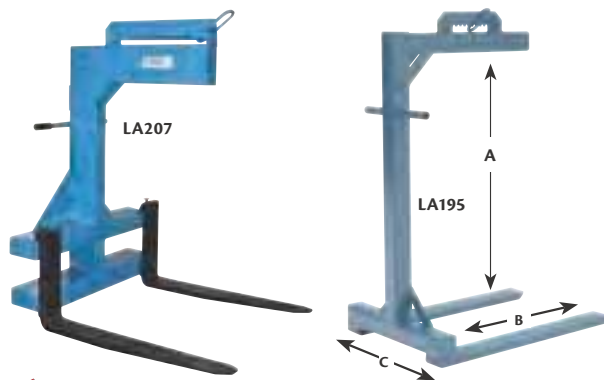

| Standard Model No. | Wt. lbs. | Adjustable Model No. | Wt. lbs. | Cap lbs. | Fork Length" |
|--------------------|----------|----------------------|----------|----------|--------------|
| LA195 | 190 | LA207 | 270 | 1000 | 36 |
| LA196 | 230 | LA208 | 295 | | 42 |
| LA197 | 255 | LA209 | 325 | | 48 |
| LA198 | 195 | LA210 | 280 | 2000 | 36 |
| LA199 | 233 | LA211 | 305 | | 42 |
| LA200 | 260 | LA212 | 335 | | 48 |
| LA201 | 310 | LA213 | 380 | 4000 | 36 |
| LA202 | 337 | LA214 | 430 | | 42 |
| LA203 | 370 | LA215 | 475 | | 48 |
| LA204 | 522 | LA216 | 575 | 6000 | 36 |
| LA205 | 662 | LA217 | 560 | | 42 |
| LA206 | 602 | LA218 | 612 | | 48 |

ECONOMICAL ADJUSTABLE PALLET LIFTERS

- Ideal for use with crane systems or with truck cranes
- Pallet lifters are available in two capacities with three adjustable or non-adjustable fork lengths to choose from

A - Throat height (clear): 48"
 B - Fork length: 36", 42" or 48"
 C - Width (O.D.): 27"



| Model No. | Cap. lbs. | Fork Length" | Wt. lbs. |
|-----------|-----------|--------------|----------|
| LT475 | 1000 | 36 | 190 |
| LT476 | 1000 | 42 | 230 |
| LT477 | 1000 | 48 | 270 |
| LT478 | 2000 | 36 | 195 |
| LT479 | 2000 | 42 | 235 |
| LT480 | 2000 | 48 | 260 |

HOSE REELS

- Suitable for air and water
- Heavy-duty, reinforced steel stampings for increased strength
- Compact design allows reels to fit in tight locations
- Multi-position guide arms for multiple mounting options
- Kinkless, oil resistant high quality hose
- Spring rewind features long life spring with declutching arbour
- Durable, corrosion-resistant powder coat paint finish



aurora tools

| Model No. | Drive Type | Hose I.D. | Hose Length' | Max PSI | Hose Outlet (M) NPT" | Reel Inlet (F) NPT" | Dimensions | | | Wt. lbs. |
|-----------|------------|-----------|--------------|---------|----------------------|---------------------|------------|----------|----------|----------|
| | | | | | | | W" | x D" | x H" | |
| TLZ482 | Spring | 1/4 | 35 | 300 | 1/4 | 3/8 | 6 | x 15 1/2 | x 14 | 26.6 |
| TLZ483 | Spring | 3/8 | 25 | 300 | 1/4 | 3/8 | 6 | x 15 1/8 | x 13 7/8 | 26.2 |
| TLZ484 | Spring | 3/8 | 35 | 300 | 1/4 | 3/8 | 6 5/8 | x 17 1/2 | x 16 1/2 | 34.7 |
| TLZ485 | Spring | 3/8 | 50 | 300 | 1/4 | 3/8 | 6 1/2 | x 20 | x 18 3/8 | 40.3 |
| TLZ486 | Spring | 1/2 | 50 | 300 | 1/2 | 1/2 | 6 5/8 | x 20 1/4 | x 17 7/8 | 44.3 |

WELDING HOSE REELS

- Heavy-duty, reinforced steel stampings for increased strength
- 1/4" oxygen and acetylene twin hose
- Leakproof double O-ring seals
- Compact design allows reels to fit in tight locations
- Multi-position guide arms for multiple mounting options
- Kinkless, oil resistant high quality hose
- Spring rewind features long life spring with declutching arbour
- Grade R hose
- Durable, corrosion-resistant powder coat paint finish



aurora tools

| Model No. | Drive Type | Hose I.D." | Hose Length' | Max PSI | Oxygen Inlet & Outlet | | Acetylene Inlet & Outlet | | Dimensions | | | Wt. lbs. |
|-----------|------------|------------|--------------|---------|-------------------------|-------------------------|--------------------------|----------|------------|------|------|----------|
| | | | | | W" | x D" | x H" | W" | x D" | x H" | | |
| TLZ487 | Spring | 1/4 | 25 | 300 | 9/16" x 18 UNF (Female) | 9/16" x 18 UNF (Female) | 8 | x 14 3/4 | x 13 5/8 | | 25.9 | |
| TLZ488 | Spring | 1/4 | 50 | 300 | 9/16" x 18 UNF (Female) | 9/16" x 18 UNF (Female) | 8 5/8 | x 20 1/2 | x 20 1/2 | | 42.2 | |

AIR/WATER DELIVERY REELS

- Lightweight and easy to handle
- Made of corrosion proof polypropylene
- Working temperature: up to 65°C
- Designed to protect the hose and allow for easy cleaning of both hose and reel
- Wall or floor mount (Floor stand not included)
- Hose included

REELCRAFT



| Model No. | Mfg. No. | Hose I.D." | Hose Length' | Max PSI | Hose Outlet (M) NPT" | Reel Inlet (F) NPT" | Dimensions" | | | Wt lbs. |
|-----------|------------|------------|--------------|---------|----------------------|---------------------|-------------|------|----------|---------|
| | | | | | | | W" | x D" | x H" | |
| FH821 | SGA36500LP | 3/8 | 50 | 232 | 3/8 | 3/8 | 9 1/8 | x 22 | x 19 3/8 | 23 |
| FH822 | SGA36650LP | 3/8 | 66 | 232 | 3/8 | 3/8 | 9 1/8 | x 22 | x 19 3/8 | 27 |
| FH823 | SGA38500LP | 1/2 | 50 | 232 | 1/2 | 1/2 | 9 1/8 | x 22 | x 19 3/8 | 27 |

HOSE REELS

- Heavy-duty, reinforced steel stampings for increased strength
- Permanently lubricated for long, trouble-free service
- Multi-position guide arms for versatile mounting options
- Kinkless, high quality hoses
- Spring rewind features long life spring with declutching arbour
- Durable, corrosion-resistant powder coat paint finish

REELCRAFT



INDUSTRIAL STEEL REELS

| Model No. | Mfg. No. | Drive Type | Hose I.D." | Hose Length' | Max PSI | Hose Outlet" (M) NPT | Reel Inlet" (F) NPT | Reel Outlet" NPT | Dimensions | | | Wt. lbs. |
|-----------|----------|------------|------------|--------------|---------|----------------------|---------------------|------------------|------------|------|------|----------|
| | | | | | | | | | W" | x D" | x H" | |

AIR OR WATER REELS FOR MANUFACTURING PLANTS, BODY SHOPS, WORKSHOPS, SERVICE STATIONS, FABRICATORS, SPRAY BOOTHS - SOLD WITH HOSE

| | | | | | | | | | | | | |
|-------|------------|--------|-----|-----|-----|-----|-----|---|--------|----------|----------|-----|
| TN315 | 4435-OLP | Spring | 1/4 | 35 | 300 | 1/4 | 3/8 | - | 5 3/8 | x 12 3/8 | x 12 7/8 | 19 |
| TN317 | 4625-OLP | Spring | 3/8 | 25 | 300 | 1/4 | 3/8 | - | 5 3/8 | x 12 3/8 | x 12 7/8 | 20 |
| TN316 | 5635-OLP | Spring | 3/8 | 35 | 300 | 1/4 | 3/8 | - | 6 | x 14 3/4 | x 14 1/2 | 25 |
| TN318 | 7650-OLP | Spring | 3/8 | 50 | 300 | 1/4 | 1/2 | - | 5 3/4 | x 19 | x 20 1/4 | 43 |
| TN319 | 7850-OLP | Spring | 1/2 | 50 | 300 | 3/8 | 1/2 | - | 5 3/4 | x 19 | x 20 1/4 | 47 |
| FI058 | 5450-OLP | Spring | 1/4 | 50 | 300 | 1/4 | 3/8 | - | 6 | x 14 3/4 | x 14 1/2 | 26 |
| FH533 | 5650-OLP | Spring | 3/8 | 50 | 300 | 1/4 | 3/8 | - | 6 | x 16 1/2 | x 17 5/8 | 36 |
| FH534 | 81100-OLP | Spring | 3/8 | 100 | 300 | 3/8 | 1/2 | - | 10 1/2 | x 24 | x 25 3/8 | 112 |
| FH490 | 82100-OLP | Spring | 1/2 | 100 | 300 | 1/2 | 1/2 | - | 10 1/2 | x 24 | x 25 3/8 | 125 |
| FH491 | 83050-OLP | Spring | 3/4 | 50 | 250 | 3/4 | 3/4 | - | 10 1/2 | x 24 | x 25 3/8 | 118 |
| FH492 | D83075-OLP | Spring | 3/4 | 75 | 250 | 3/4 | 3/4 | - | 14 1/4 | x 24 | x 25 3/8 | 132 |
| FH493 | D84050-OLP | Spring | 1 | 50 | 250 | 3/4 | 1 | - | 15 1/4 | x 24 | x 25 3/8 | 133 |
| FH494 | E9350-OLP | Spring | 3/4 | 50 | 250 | 3/4 | 3/4 | - | 15 3/4 | x 26 1/4 | x 26 1/4 | 170 |
| FH495 | E9450-OLP | Spring | 1 | 50 | 250 | 3/4 | 1 | - | 15 3/4 | x 26 1/4 | x 26 1/4 | 187 |

HAND CRANK FOR AIR OR WATER - DESIGNED FOR MEDIUM-DUTY APPLICATIONS REQUIRING LONGER LENGTHS OF HOSE - SOLD WITHOUT HOSE

| | | | | | | | | | | | | |
|-------|----------|--------|-----|-----|------|---|-----|---------|--------|----------|----------|----|
| FH506 | CA32106L | Manual | 1/2 | 100 | 1000 | - | 1/2 | 1/2 (F) | 19 3/4 | x 17 3/4 | x 20 1/4 | 40 |
| FH507 | CA32112L | Manual | 1/2 | 200 | 1000 | - | 1/2 | 1/2 (F) | 25 3/4 | x 17 3/4 | x 20 1/4 | 46 |
| FH508 | CA33112L | Manual | 3/4 | 100 | 1000 | - | 3/4 | 3/4 (F) | 19 3/4 | x 17 3/4 | x 20 1/4 | 46 |
| FI060 | CA37118L | Manual | 1 | 100 | 300 | - | 1 | 1 (M) | 34 | x 17 3/4 | x 20 1/4 | 58 |